

Standards

IEC 60947-1 explains the general rules relating to **Low voltage switchgear and controlgear**. The purpose of this standard is to harmonize as much as possible the product performance and test requirements for equipment where the rated voltage does not exceed 1000 Vac or 1500 Vdc.

IEC 60947-5-1 is part 5 of the general rules which relates to **Control-circuit devices and switching elements** where rated voltage does not exceed 1000 Vac or 600 Vdc. Also within this part there is a section which considers **Special Requirements For Control Switches With Positive Opening Operation**. Any control switch which has this positive opening operation and conforms to these special requirements will be marked on the outside of the product with this symbol:



Positive Opening Operation

All the switches presented in this catalog feature positive opening contacts on the **Normally Closed Circuits** (see Notes). These circuits are identified in this literature by the positive opening symbol shown above. Positive opening ensures that should the NC contacts weld, they can be forced apart by normal operation of the switch, i.e. depressing the plunger, removing the key, rotating the lever or pulling on the cable. In other words, an open circuit is guaranteed even after an electrical fault condition has occurred. Although it should be usual practice to protect the NC safety circuit with a fuse of an appropriate rating for the control current being used, if this additional security is shorted out or bypassed, the positive opening feature ensures that the contacts will separate.

The positive opening feature is specified within **EN 60947-5-1** chapter 3 sometimes referred to as **EN 60947-5-1-3**. The standard gives general requirements for the electrical current, voltage rating and life characteristics of **Low Voltage (120 to 1000 V) Switchgear**. What distinguishes **Safety Switches** from standard switches is their ability to meet the requirements of chapter 3, which describes the requirements for positive opening operation. There are two main elements to positive opening operation;

1. There should be no "flexible members" within the drive train operating the positive operating contacts – this means that **wobble or flexible actuators** cannot be used.
2. The basic switch shall incorporate a mechanism which will guarantee positive opening of the NC circuit. Both the **Snap Action** and **Slow Acting** basics used on our safety range incorporate this design feature. The tests performed to confirm that the positive opening mechanism complies with the requirements of chapter 3 include:

a) Passing 1000 A, at 110% of the rated voltage, through the contacts. This current flows until a protective fuse, in series with the contacts, is blown. The switch is operated using the minimum force and travel published in our installation sheet. These first two steps are repeated twice. Finally the contact separation is confirmed using a 2,5 kV dielectric test.

b) Verifying the contact robustness by applying a 10 N force to the moving contact and ensuring any distortion does not affect the switch's dielectric properties.

c) Operating the switch at the maximum specified current, in the maximum specified ambient temperature and confirming the switch's dielectric properties are not reduced.

Only when these tests have been successfully concluded can a switch claim positive opening. To ensure complete impartiality of the performance we claim, Honeywell had these tests carried out by an independent third party test house.

Notes:

- **Normally Open (NO)** contacts rely on spring mechanisms to open the circuit. If a weld occurs on these contacts there is no guarantee the contacts will separate. Due to this limitation these contacts are normally used for monitoring purposes and shall not form part of the safety circuit.
- **Normally Closed (NC)** contacts are those which make circuit when either:
 - **The Switch** is not actuated -i.e. neither depressed nor rotated
 - or
 - **The Key** is inserted -i.e. the guard is closed
 - or
 - **The Cable** is up to tension but not pulled or cut
- The installation sheet provided with each product states the minimum required operating force and travel to ensure positive opening. It is essential that the mechanism employed to operate the switch can generate both the minimum and maximum required force and travel, and the extra travel needed to rotate the mechanism is available, but limited so as not to damage the mechanism.

Further information on design requirements of positive opening **Switchgear** and the **Low Voltage Directive** can be found in **IEC 60947-5-1/EN 60947-5-1, EN 1088 and EN 954**. The **Machinery Directive 98/37/EC** also gives further guidance.

The Contact Element Form defines the configuration of the contacts and the number of contacts within the switch:

Form Za - both contact elements have the same polarity.

Form Zb - the two contact elements are electrically separated.

The **Utilization Category** defines the type of current carried (ac) Alternating current, (dc) direct current and the typical application in which the switch is used:

Ac15 - Control of Electromagnetic Loads (less than 72 VA)

Dc13 - Control of electromagnets.

The contact rating **Designation** relates to the utilization categories and defines the conventional thermal current I_{th} (A), rated operational current I_e (A) at rated operational voltages U_e and the VA rating:

A600 - The "A" denotes the maximum VA rating (ac) and the "600" denotes the maximum rated (ac) voltage.

Q300 - The "Q" denotes the maximum VA rating (dc) and the "300" denotes the maximum rated (dc) voltage.

These IEC standards have been adopted by CENELEC (The European Committee for Electrotechnical Standardization) and have been identified by replacing IEC with EN 60:

IEC 60947-5-1 then becomes **EN 60947-5-1**

CENELEC has defined the dimensions and characteristics of two types of limit switch in the standards **EN 50041** and **EN 50047**.

These standards relate to **Low voltage switchgear and controlgear for industrial use** and define the enclosure dimensions, the operating point for various head actuators, the earth terminal requirement, the terminal marking, and the minimum degree of IP protection.

Electrical Rating

IEC 60947-5-1/EN 60947-5-1									
Designation & Utilization Category	Rated operational current I_e (A) at rated operational voltage U_e							VA rating	
	120 V	240 V	380 V	480 V	500 V	600 V	Make	Break	
Ac15 A600	6	3	1,9	1,5	1,4	1,2	7200	720	
Ac15 A300	6	3	-	-	-	-	7200	720	
Ac15 B300	3	1,5	-	-	-	-	3600	360	
Ac14 D300	0,6	0,3	-	-	-	-	432	72	
	125 V	250 V							
Dc13 Q300	0,55	0,27					69	69	
Dc13 R300	0,22	0,1					28	28	

Proper application of electromechanical switches

For electromechanical switches with pushrod actuators, the actuating force should be applied as nearly as possible in line with the pushrod axis.

Cam or dog arrangements should be such that the actuator is not suddenly released to snap back freely.

Operating mechanisms for electromechanical switches should be so designed that, under any operating or emergency conditions, the electromechanical switch is not operated beyond its overtravel electromechanical position. An electromechanical switch should not be used as a mechanical stop.

For electromechanical switches with lever actuators, the actuating force should be applied as nearly perpendicular to the lever as practical and perpendicular to the shaft axis about which the lever rotates.

Degree of protection

IP Classification

The IEC 60529 standard describes a system for classifying the degree of protection provided by the enclosures of electrical equipment.

The level of protection given by the enclosure is indicated by the IP code.

This code system uses the letters "IP" (International Protection) followed by up to four digits normally only the first two digits are used.



First Digit	Protection against ingress of solid objects
IP	TEST
0	no protection
1	protected against solid objects with a diameter greater than 50 mm
2	protected against solid objects with a diameter greater than 12 mm
3	protected against solid objects with a diameter greater than 2.5 mm
4	protected against solid objects with a diameter greater than 1 mm
5	protected against dust-limited ingress (no harmful deposit)
6	totally protected against dust

Second Digit	Protection against ingress of water
IP	TEST
0	no protection
1	protected against vertically falling drops of water
2	protected against vertically falling drops of water when the enclosure is tilted at an angle up to 15 degrees
3	protected against water sprayed at an angle of 60 degrees from the vertical
4	protected against splashing water from all directions - limited ingress (no harmful effects)
5	protected against low pressure jets of water from all directions - limited ingress permitted
6	protected against powerful jets of water from all directions - limited ingress permitted
7	protected against the effects of temporary immersion in water
8	protected against the effects of continuous immersion in water

The first digit is numerical and indicates the level of protection within the enclosure against the ingress of solid foreign objects and access to hazardous parts by persons.

The second digit is also numerical and indicates the level of protection against the ingress of **WATER** into the enclosure.

The third digit is a letter and indicates a higher level of protection for persons against access to hazardous parts.

The fourth digit is also a letter and is used in exceptional cases for supplementary information.

If the first or second digit is not required to be specified, then it is replaced by the letter "X" ("XX" if both digits are not required).

While the tables below serve as a guide to the level of protection, Honeywell recommends that customers refer to the full official IEC specification for the exact definitions. If in doubt about the degree of protection required for a particular application, please consult your local Honeywell office and your safety and regulatory advisors.

Note: The IEC 60529 standard does not relate to protection against rust, corrosion, icing or corrosive solvents (e.g. cutting fluids) and that product coded IP 67 may not necessarily meet IP 66 requirements.

NEMA Classification (USA)

NEMA (National Electrical Manufacturer's Association) prepares standards which define a product, process or procedure with reference to one or more of the following: nomenclature, composition, construction, dimensions, tolerances, safety, operating characteristics, performance, quality, electrical rating, testing and the service for which designed.

This standard provides degrees of protection for Enclosures for Electrical Equipment (1000 Volts Maximum) similar to that of the IEC 60529 standard. The reference standard herein reflects the latest data in the NEMA Standards Publication when this information pack went to print.

Non-hazardous locations

Type 1 enclosures are intended for indoor use primarily to provide a degree of protection against contact with the enclosed equipment.

Type 3 enclosures are intended for outdoor use primarily to provide a degree of protection against windblown dust, rain, sleet, and external ice formation.

Type 4 enclosures are intended for indoor or outdoor use primarily to provide a degree of protection against windblown dust and rain, splashing water, and hose-directed water.

Type 4X enclosures are intended for indoor or outdoor use primarily to provide a degree of protection against corrosion, windblown dust and rain, splashing water, and hose-directed water.

Type 6 enclosures are intended for indoor or outdoor use primarily to provide a degree of protection against the entry of water during occasional temporary submersion at a limited depth.

Type 6P enclosures are intended for indoor or outdoor use primarily to provide a degree of protection against the entry of water during prolonged submersion at a limited depth.

Type 12 enclosures are intended for indoor use primarily to provide a degree of protection against dust, falling dirt, and dripping non-corrosive liquids.

Type 13 enclosures are intended for indoor use primarily to provide a degree of protection against dust, spraying water, oil and non-corrosive coolant.

Note: Enclosures are based, in general, on the broad definitions outlined in NEMA Standards. Therefore, it will be necessary to ascertain that a particular enclosure will be adequate when exposed to the specific conditions that might exist in intended applications. Except as might otherwise be noted, all references to products relative to NEMA enclosure type are based on Honeywell evaluation and Underwriter's Laboratory (UL) tested.

This NEMA Standards Publication does test for environmental conditions such as corrosion, rust, icing, oil, and coolants. The IEC 60529 does not, and does not specify degree of protection against mechanical damage of equipment. For this reason, and because the tests and evaluations for other characteristics are not identical, the IEC Enclosure Classification Designations cannot be exactly equated with NEMA Enclosure Type Numbers.

How to read and understand the bar chart information

The following example relates to a unit which has a snap action basic and which has a roller pin plunger actuator i.e. GSAB01C. When reading these bar charts follow these rules:

1. Check what type of actuator was used to test the product, this is on the drawings which show the head style available.
It will be one of two types:
a) Vertical travel plunger
b) Linear cam travel

2. Start reading from top left of figure B, at the arrow labelled "A".
3. Follow the black arrows and the black strip on the chart. The black strip indicates that there is a circuit between the terminals whose numbers are shown on the left and when white there is no circuit.

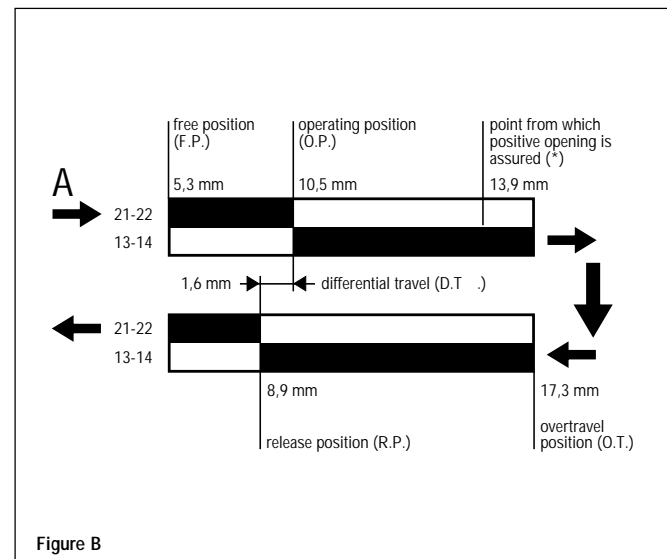
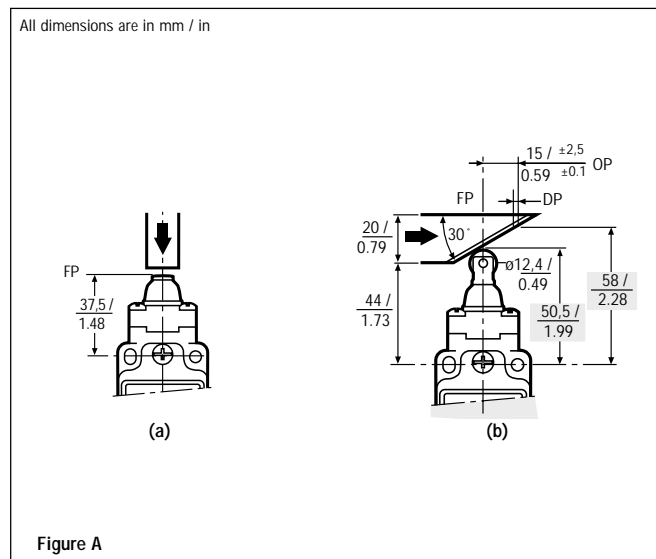

Look at Figures A and B as examples. Actuator type used for test is the linear Cam travel type (b) shown left. The start point is at the arrow marked "A" (See fig. B). This shows the free position to be 5,3 mm from the vertical centre line of the unit. At this stage there is a circuit between the terminals 21-22 but no circuit between terminals 13-14. The unit can be actuated until it reaches the operating position which is 10,5 mm from the centre line - a travel distance of $10,5 - 5,3 = 5,2$ mm from the free position. At this point the circuit arrangement changes - no circuit between 21-22 but making a circuit between 13-14. If, however, the contacts of terminals 21-22 weld together and will not separate, a mechanical safety feature will take effect if the switch is travelled past the point from which positive opening is assured, 13,9 mm. As the switch returns it reaches the release position at 8,9 mm from the centre line. The circuit will change back to the original state and the difference between the operating position and the release position gives what is known as the differential travel i.e. $10,5 - 8,9 = 1,6$ mm. The asterisk (*) indicates the point from which the positive opening is assured.

Note to figure B

Key:
 F.P. = Free Position
 O.P. = Operating Position
 R.P. = Release Position
 D.T. = Differential Travel
 O.F. = Operating Force
 R.F. = Release Force