

Technical Note

SPI Communication with Honeywell Digital Output Pressure Sensors

1.0 Introduction

The Serial Peripheral Interface (SPI) is a simple bus system for synchronous serial communication between one master and one or more slaves. It operates either in full-duplex or half-duplex mode, allowing communication to happen in either both directions simultaneously, or in only one direction. The master device initiates an information transfer on the bus and generates clock and control signals. Slave devices are controlled by the master through individual slave select lines and are active only when selected.

Honeywell pressure sensors with SPI output operate in half-duplex mode only, with data transfer from the slave to the master (Figure 1). For this data transmission three lines need to be used:

1. Slave Select (SS)
2. Signal Clock (SCLK)
3. Master In - Slave Out (MISO)

These three bus lines are all unidirectional. SCLK and SS are controlled by the master while MISO is controlled by the slave.

Figure 1. SPI Bus Configuration

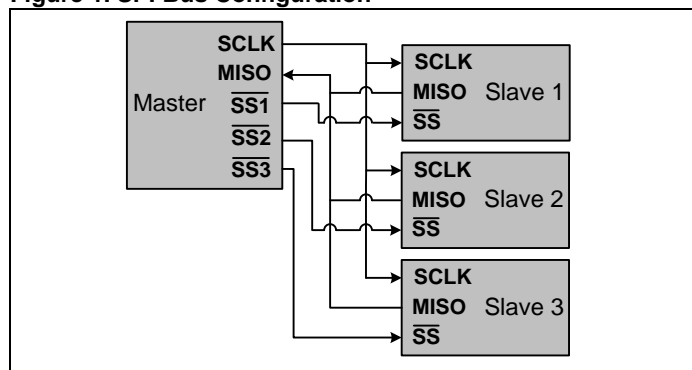

2.0 Data Transfer with SPI Output Pressure Sensors

Starting communication with Honeywell SPI output pressure sensors begins by deasserting the SS line. At this point, the sensor is no longer idle, and will begin sending data once a clock is received.

Honeywell digital output pressure sensors are configured for operation such that data on the MISO line will transition during the falling edge of clock pulses. This means that the data on MISO should be sampled by the master device during the rising edge of the clock pulse.

Figure 2 shows an example of a 1 byte data transfer from the slave to the master. In this example, the data 101 (01100101 binary, or 65 hex) would be the result of the read.

Figure 2. Example of a 1 Byte SPI Data Transfer with Honeywell Pressure Sensors

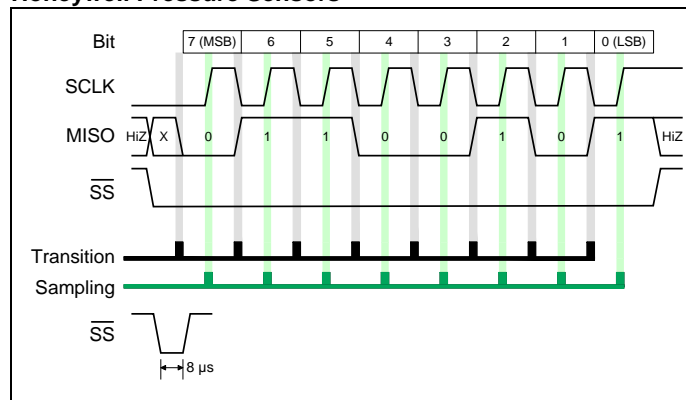

Once the clocking begins, Honeywell digital output pressure sensors are designed to output up to 4 bytes of data, depending on the sensor options and the needs of the application. In all cases, the first two data bytes are the compensated pressure output, along with sensor status bits. The third and fourth bytes are for optional compensated temperature output.

2.1 Pressure Reading

To read out a compensated pressure reading, the master generates the necessary clock signal after activating the sensor with the slave select line. The sensor will transmit up to 4 bytes of data – the first two bytes containing the compensated pressure output, and the second two bytes containing the optional compensated temperature output. The master can terminate the communication by stopping the clock and deactivating the slave select line. Examples of the communication are shown in Figure 3.

SPI Communication with Honeywell Digital Output Pressure Sensors

Figure 3. SPI Pressure and Temperature Packets

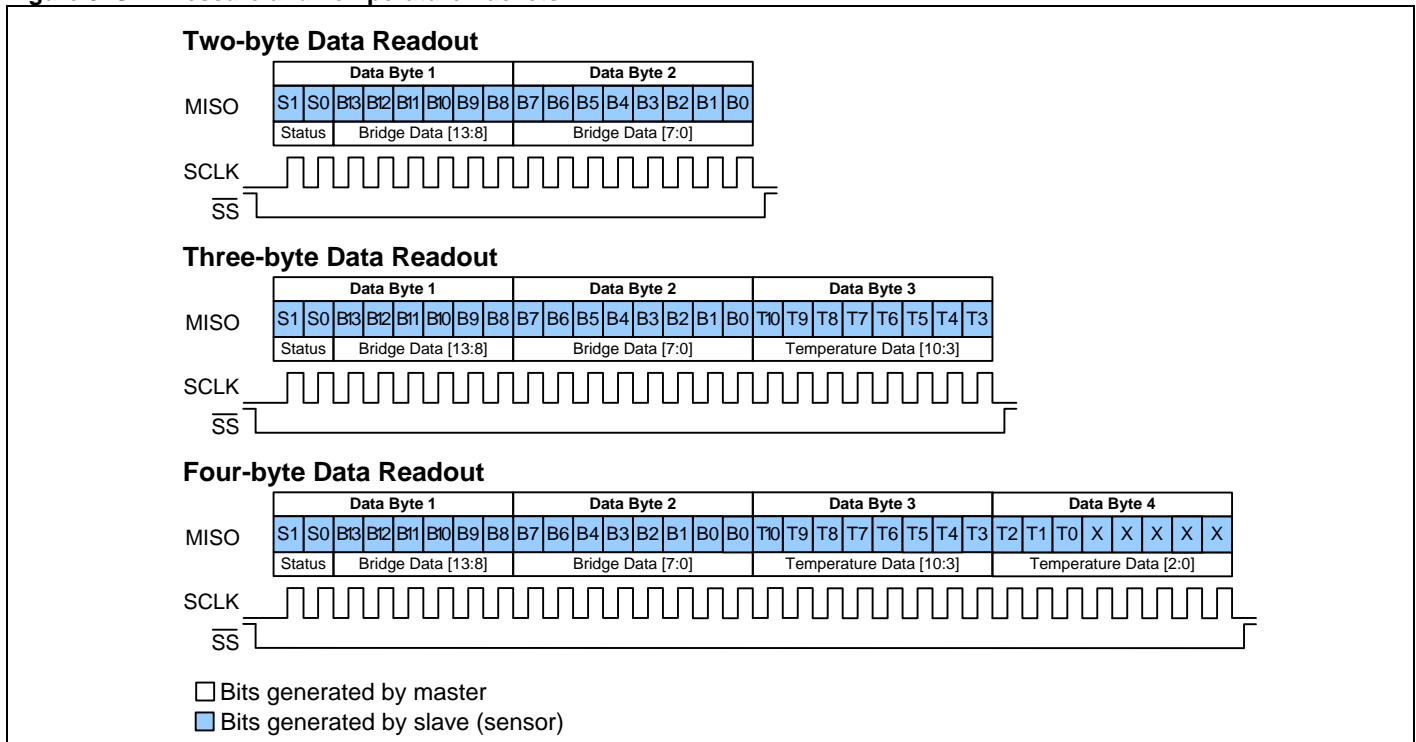

Note: For sensors that do not offer the optional compensated temperature output, the sensor will still output the third and fourth bytes of data. The information contained in these bytes is non-corrected data, and should not be used.

2.2 Temperature Reading

The optional corrected temperature data can be read out with either 8 bit or 11 bit resolution. By reading out the third byte of data from the sensor, the 8 bit compensated temperature value can be read. Further, by reading out the fourth byte of data, the complete 11 bit optional compensated temperature value can be read. The 8 bit value gives an approximate 0.8 °C resolution, while the 11 bit value gives an approximate 0.1 °C resolution.

When reading the full 11 bit resolution temperature output, the 5 least significant bits of the fourth data byte are “Do Not Care” and should be ignored.

2.3 Status Bits

Honeywell digital output pressure sensors offer both standard and optional diagnostics to ensure robust system operation in critical applications. The diagnostic states are indicated by the first two Most Significant Bits of data byte 1.

Four diagnostic states are indicated by the 2 status bits (Table 1).

Table 1. Diagnostic Conditions indicated by Status Bits

Status Bits		Definition
S1	S0	
0	0	normal operation, valid data
0	1	device in command mode*
1	0	stale data: data that has already been fetched since the last measurement cycle, or data fetched before the first measurement has been completed
1	1	diagnostic condition

Note: *Command Mode is used for programming the sensor. This mode should not be seen during normal operation.

Standard diagnostics for Honeywell digital output pressure sensors consists of an EEPROM (Electrically Erasable Programmable Read-Only Memory) signature used to validate the EEPROM contents during startup. In the event that any EEPROM contents change after calibration, a diagnostic condition will be flagged.

Optional diagnostics for Honeywell digital output pressure sensors consist of:

- Loss of sense element connection
- Short circuit of sense element

SPI Communication with Honeywell Digital Output Pressure Sensors

When the two status bits are “11”, one of the above mentioned diagnostic faults is indicated.

When the status bits read “10”, “stale” data is indicated, this means that the data that already exists in the sensor’s output buffer has already been fetched by the master, and has not yet been updated with the next data from the current measurement cycle. This can happen when the master polls the data quicker than the sensor can update the output buffer.

(Please contact Honeywell Customer Service with questions regarding the availability of optional digital output pressure sensor diagnostics.)

3.0 Calculation of the Pressure from the Digital Output

For Honeywell digital output pressure sensors, the output of the device can be expressed by the transfer function of the device as shown in Equation 1.

Equation 1: Pressure Sensor Transfer Function

$$\text{Output} = \frac{\text{Output}_{\text{max}} - \text{Output}_{\text{min}}}{P_{\text{max}} - P_{\text{min}}} \cdot (\text{Pressure} - P_{\text{min}}) + \text{Output}_{\text{min}}$$

Rearranging this equation to solve for Pressure, we get Equation 2:

Equation 2: Pressure Output Function

$$\text{Pressure} = \frac{(\text{Output} - \text{Output}_{\text{min}}) \cdot (\text{Pressure}_{\text{max}} - \text{Pressure}_{\text{min}})}{(\text{Output}_{\text{max}} - \text{Output}_{\text{min}})} + \text{Pressure}_{\text{min}}$$

Where:

- Output_{max} = output at max. pressure [counts]
- Output_{min} = output at min. pressure [counts]
- Pressure_{max} = max. value of pressure range [bar, psi, kPa, etc.]
- Pressure_{min} = min. value of pressure range [bar, psi, kPa, etc.]
- Pressure = pressure reading [bar, psi, kPa, etc.]
- Output = digital pressure reading [counts]

As an example, the pressure will be calculated for a -1 psi to 1 psi differential sensor with a 10% to 90% calibration and a pressure output of 1657 (decimal) counts:

- Output_{max} = 14745 counts (90% of 2¹⁴ counts or 0x3999)
- Output_{min} = 1638 counts (10% of 2¹⁴ counts or 0x0666)
- Pressure_{max} = 1 psi
- Pressure_{min} = -1 psi
- Pressure = pressure in psi
- Output = 1657 counts

$$\left\{ \begin{array}{l} \text{Pressure} = \left[\frac{(1657 - 1638) \cdot (1 - (-1))}{(14745 - 1638)} \right] + (-1) \\ \text{Pressure} = \left[\frac{(19) \cdot (2)}{13107} \right] + (-1) \\ \text{Pressure} = \left[\frac{38}{13107} \right] + (-1) \\ \text{Pressure} = (0.002899) + (-1) \\ \text{Pressure} = -0.997 \text{ psi} \end{array} \right.$$

4.0 Calculation of Optional Temperature from the Digital Output

For Honeywell digital output pressure sensors with the optional compensated temperature output, the output can be converted to degrees C using Equation 3:

Equation 3: Temperature Conversion Function

$$\text{Temperature (}^\circ\text{C)} = \left(\frac{\text{Output (dec)}}{2047} \cdot 200 \right) - 50$$

If the 8 bit temperature output is used, the data must first be shifted left by 3 bits and have the 3 Least Significant Bits set to “0’s” for the equation to work.

As an example, the optional compensated temperature output will be calculated for a sensor with an 8 bit temperature output of 255:

Step 1: Left shift the above 8-bit value by 3 places and append the 3 LSBs with 0s:

$$\text{Digital Temperature Output (8 – bit)} = 255 = 11111111\text{b}$$

$$11111111000\text{b} = 2040$$

Step 2: Use the adjusted value and plug into Equation 3:

$$\text{Temperature} = \left(\frac{2040}{2047} \cdot 200 \right) - 50$$

$$\text{Temperature} = 149.31^\circ\text{C}$$

As a second example, the optional compensated temperature output will be calculated for a sensor with an 11 bit temperature output of 1456:

Step 1: Plug the digital temperature output value into Equation 3:

$$\text{Temperature} = \left(\frac{1456}{2047} \cdot 200 \right) - 50$$

$$\text{Temperature} = 92.26^\circ\text{C}$$

SPI Communication with Honeywell Digital Output Pressure Sensors

5.0 Timing and Level Parameters

Table 2. Parameters for SPI Bus Communication with Honeywell Digital Output Pressure Sensors

SPI Parameter	Symbol	Min.	Typ.	Max.	Unit
SCLK clock frequency	f _{SCL}	50	-	800	kHz
SS drop to first clock edge	t _{HDSS}	2.5	-	-	μs
Minimum SCLK clock low width*	t _{LOW}	0.6	-	-	μs
Minimum SCLK clock high width*	t _{HIGH}	0.6	-	-	μs
Clock edge to data transition	t _{CLKD}	0	-	-	μs
Rise of SS relative to last clock edge	t _{SSUS}	0.1	-	-	μs
Bus free time between rise and fall of SS	t _{BUS}	2	-	-	μs
Output level low	Out _{low}	-	0	0.2	VDD
Output level high	Out _{high}	0.8	1	-	VDD

Note: *Combined low and high widths must equal or exceed minimum SCL period.

Figure 3: SPI Bus Timing Diagram

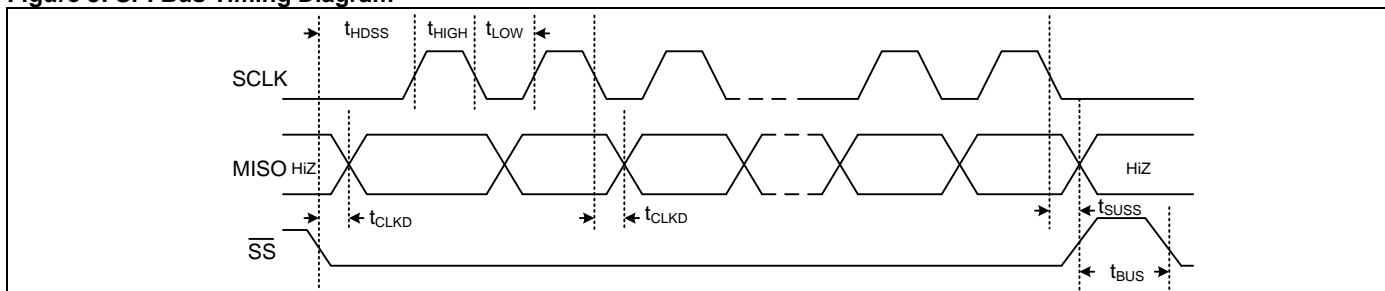

WARNING
PERSONAL INJURY
 DO NOT USE these products as safety or emergency stop devices or in any other application where failure of the product could result in personal injury.
Failure to comply with these instructions could result in death or serious injury.

WARRANTY/REMEDY
 Honeywell warrants goods of its manufacture as being free of defective materials and faulty workmanship. Honeywell's standard product warranty applies unless agreed to otherwise by Honeywell in writing; please refer to your order acknowledgement or consult your local sales office for specific warranty details. If warranted goods are returned to Honeywell during the period of coverage, Honeywell will repair or replace, at its option, without charge those items it finds defective. **The foregoing is buyer's sole remedy and is in lieu of all other warranties, expressed or implied, including those of merchantability and fitness for a particular purpose. In no event shall Honeywell be liable for consequential, special, or indirect damages.**

While we provide application assistance personally, through our literature and the Honeywell web site, it is up to the customer to determine the suitability of the product in the application.

Specifications may change without notice. The information we supply is believed to be accurate and reliable as of this printing. However, we assume no responsibility for its use.

WARNING
MISUSE OF DOCUMENTATION
 • The information presented in this technical note sheet is for reference only. DO NOT USE this document as a product installation guide.
 • Complete installation, operation, and maintenance information is provided in the instructions supplied with each product.
Failure to comply with these instructions could result in death or serious injury.

SALES AND SERVICE
 Honeywell serves its customers through a worldwide network of sales offices, representatives and distributors. For application assistance, current specifications, pricing or name of the nearest Authorized Distributor, contact your local sales office or:

E-mail: info.sc@honeywell.com

Internet: www.honeywell.com/sensing

Phone and Fax:
 Asia Pacific +65 6355-2828
 +65 6445-3033 Fax
 Europe +44 (0) 1698 481481
 +44 (0) 1698 481676 Fax
 Latin America +1-305-805-8188
 +1-305-883-8257 Fax
 USA/Canada +1-800-537-6945
 +1-815-235-6847
 +1-815-235-6545 Fax