

Hall-effect Open-loop Current Sensor Application

Application Sheet

POTENTIAL APPLICATIONS

Production

- Machine tool
- Printing
- Paper
- Textile
- Plastic injection
- Rolling
- Cranes
- Robotics
- Pumps
- Battery chargers
- Fork lift trucks
- Electrolysis and electrochemistry
- Heating
- Energy management systems
- Smart building

Home Appliances

- Washing machine
- Air conditioner
- Microwave oven
- Vacuum cleaner

Public Appliances

- Wind mill
- Escalators and lifts
- Electrical opening doors system

Transportation

- Electric vehicles (zero-emission vehicles)
- Current measurement in traction
- Points-operation monitoring in trackside system

Power

- Power network failure recording & harmonic analyze
- Electronic ballast
- Battery monitoring
- Solar power

Medical

- Electrical wheel chairs
- X-ray
- CT and other imaging equipments

FEATURE AND BENEFITS

- No insertion losses for primary circuit
- Low power consumption
- Voltage output (basic) and multi-options
- Single or dual power supply
- Compact package size
- Low weight
- Perfect performance/price ratio

1. CURRENT SENSOR PRINCIPLE

1.1 Hall Effect Principle

The Hall effect was discovered by Dr. Edwin Hall in 1879 while he was a doctoral candidate at Johns Hopkins University in Baltimore. Dr. Hall found when a magnet was placed so that its field was perpendicular to one face of a thin rectangle of gold through which current was flowing, a difference in potential appeared at the opposite edges. He found that this voltage was proportional to the current flowing through the conductor, and the flux density or magnetic induction perpendicular to the conductor.

When a current-carrying conductor is placed into a magnetic field, a voltage will be generated perpendicular to both the current and the field. This principle is known as the Hall effect.

Figure 1-1 illustrates the basic principle of the Hall effect. It shows a thin sheet of semiconducting material (Hall element) through which a current is passed. The output connections are perpendicular to the direction of current. When no magnetic field is present (Figure 1-1), current distribution is uniform and no potential difference is seen across the output.

Figure 1.1 Hall-effect basic principle

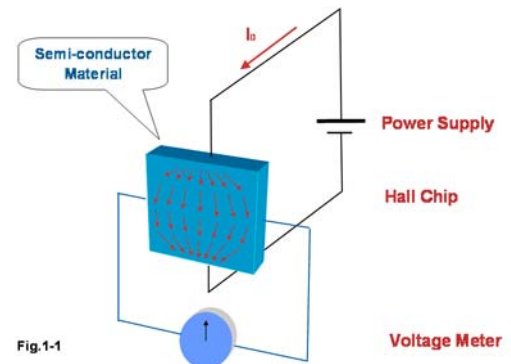

When a perpendicular magnetic field is present, as shown in Figure 1-2, a Lorentz force is exerted on the current. This force disturbs the current distribution, resulting in a potential difference (voltage) across the output. This voltage is the Hall voltage (V_H). The interaction of the magnetic field (B) and the drive current (I_D) is shown in equation form as equation 1-1. The formula as below:

$$V_H \propto I_D \times B \quad \text{Formula (1-1)}$$

Hall-effect Open-loop Current Sensor Application

Hall effect sensors can be applied in many types of sensing devices. If the quantity (parameter) to be sensed incorporates or can incorporate a magnetic field, a Hall sensor will perform the task.

Figure 1.2 Presence of a perpendicular magnetic field

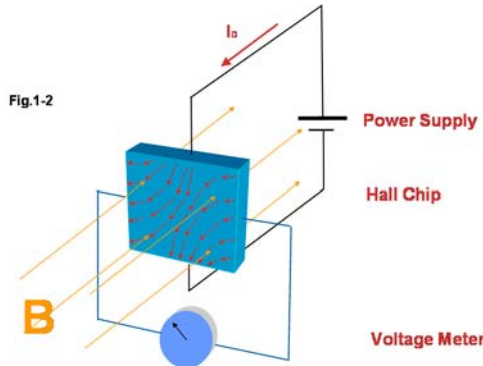

1.2 Current Sensor Operation

As we know, when a current (primary current I_p) flows through a conductor, it creates a magnetic field around the conductor. The magnetic field is direct proportion to the current level. Using a core made with soft magnetic material around the primary conductor, almost all of the magnetic field is concentrated in the core. Cutting an air-gap in the core and putting a Hall in the gap allows the magnetic density to be sensed, and the Hall voltage (V_H) is direct proportion to the primary current (I_p). The formula as below:

$$V_H \propto I_D \times B,$$

Then, $V_H \propto I_D \times I_p$ Formula (1-2)

If the drive current (I_D) is controlled using a constant current source and the differential Hall voltage amplified, an output voltage proportional to I_p only can be obtained by the electronics circuit. Figure 1-3 illustrates the basic principle and structure of the Hall effect open-loop current sensor.

Figure 1.3 Formula illustration

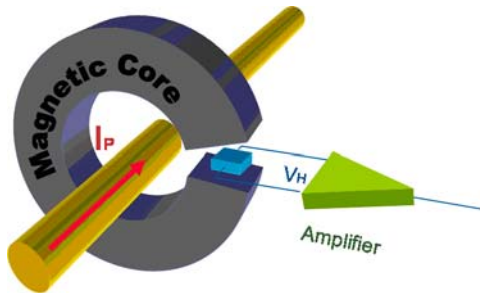

2.0 NOMENCLATURE

- All sensors are rated -40 °C to +85 °C [-40 °F to 185 °F] operating range unless otherwise defined via a 3-digit number at the end of the listing.
- All sensors use UL recognized materials, and all plastics and wire insulation is to UL94-V0.

CSCA NNNN H YYY XNN Y 00

| | |
|-------------|---|
| CSC | Current sensor C series |
| A | Alphabetic designator defining operating principle A: Hall-effect open loop B: Hall-effect close loop C: Flux-gate open loop D: Flux-gate close loop E: MR-effect open loop F: MR-effect close loop G: Transformer-effect H: Resistance-effect |
| NNNN | 4-digit designator for nominal current rating Examples: 0025 = 25 A rms; 0300 = 300 A rms |
| H | Alphabetic designator for housing/casing style |
| YYY | 3-digit designator defining the number of coil turns (closed loop sensors only) Digit 1: Base number of turns (e.g. 1, 2, 3 etc.) Digit 2: Supplementary number of turns (e.g. 5) Digit 3: 10 to the power multiplier Examples: 202 = 2000 352 = 3500 502 = 5000 301 = 300 000 = Not Applicable |
| XNN | Alphanumeric designator for power supply If letter, B: Bipolar (+/-) supply U: Unipolar (+) supply M: Mains supply voltage If Letter = B or U : defines dc voltage supply Example: B05= ±5 Vdc If Letter = M : Defines ac voltage supply with x 1.0 multiplier Example: M11=110 Vac |
| Y | Alphabetic designator defining the output signal function A: Current ratio output B: ±4 V C: ±5 V D: 0.5 V to Vcc-0.5 V E: 4 mA to 20 mA F: 12 ±8 mA G: Digital output H: Serial output J: 3 ±2 V |
| 00 | 2-digit designator representing special modifications not affecting the basic form or function of the sensor |

Hall-effect Open-loop Current Sensor Application

3.0 Application Schematics

3.1 ac variable speed drives and Servo motor drives

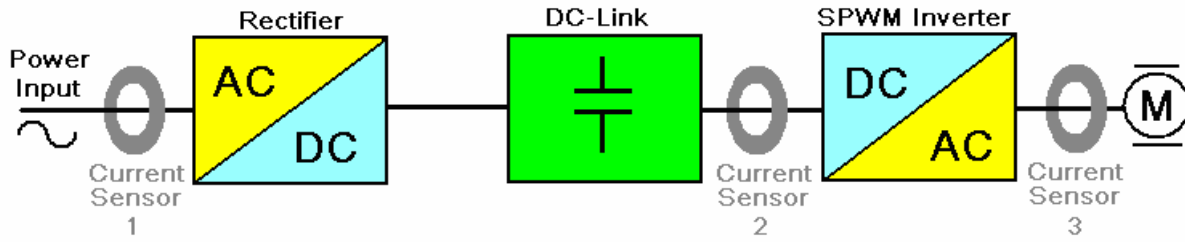

3.2 Static converters for dc motor drives

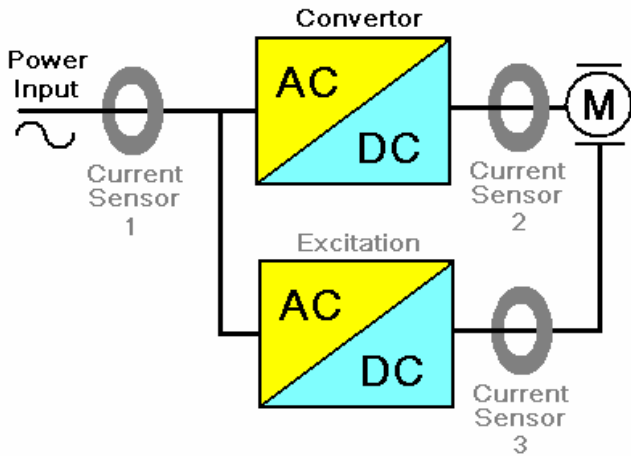

3.3 Backup power supply system monitor

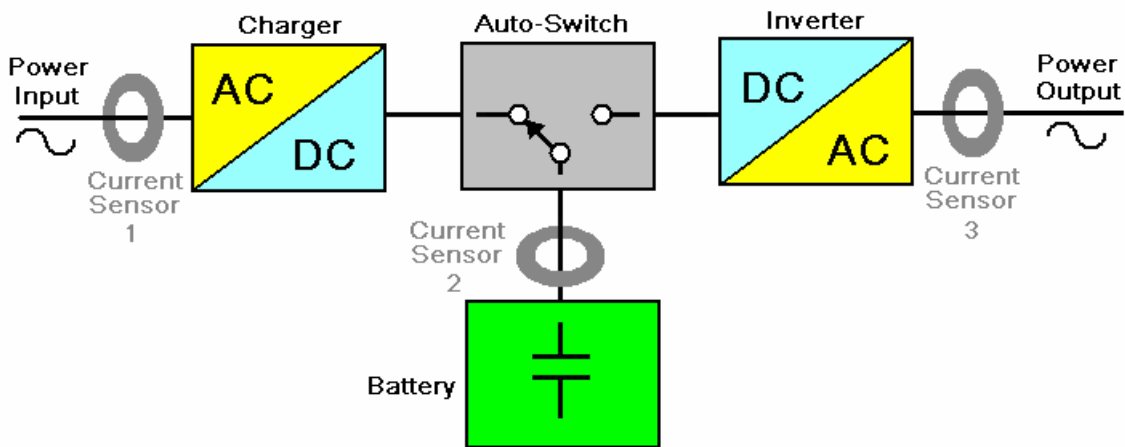

Hall-effect Open-loop Current Sensor Application

3.4 Online-uninterruptible power supply monitor

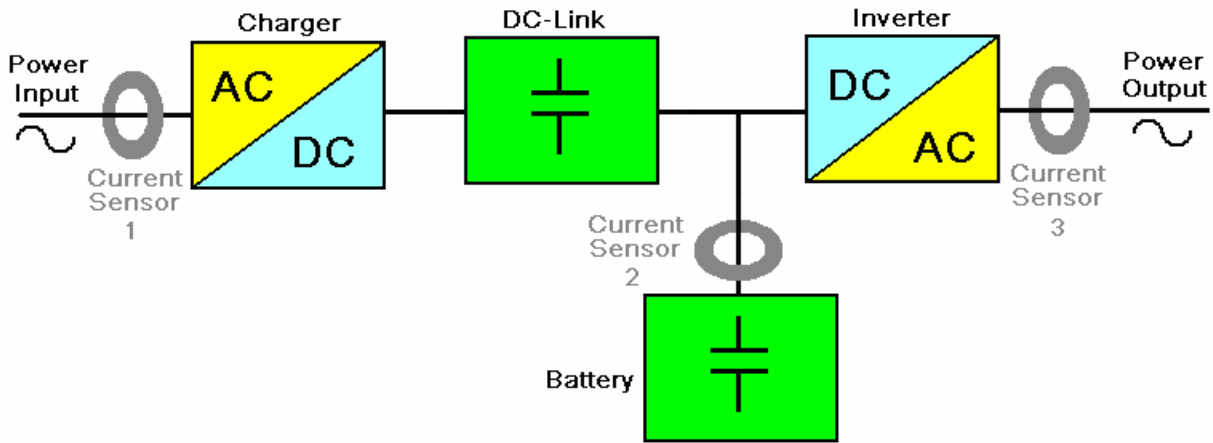

3.5 Switched mode power supplies and dc welding

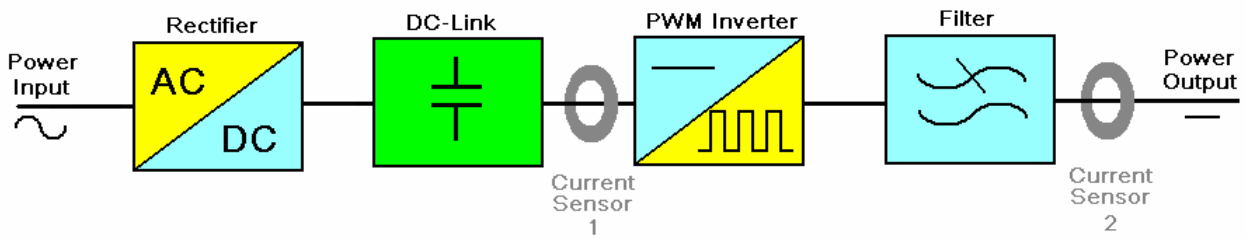

Hall-effect Open-loop Current Sensor Application

WARNING

PERSONAL INJURY

DO NOT USE these products as safety or emergency stop devices or in any other application where failure of the product could result in personal injury.

Failure to comply with these instructions could result in death or serious injury.

WARRANTY/REMEDY

Honeywell warrants goods of its manufacture as being free of defective materials and faulty workmanship. Honeywell's standard product warranty applies unless agreed to otherwise by Honeywell in writing; please refer to your order acknowledgement or consult your local sales office for specific warranty details. If warranted goods are returned to Honeywell during the period of coverage, Honeywell will repair or replace, at its option, without charge those items it finds defective. **The foregoing is buyer's sole remedy and is in lieu of all other warranties, expressed or implied, including those of merchantability and fitness for a particular purpose. In no event shall Honeywell be liable for consequential, special, or indirect damages.**

While we provide application assistance personally, through our literature and the Honeywell web site, it is up to the customer to determine the suitability of the product in the application.

Specifications may change without notice. The information we supply is believed to be accurate and reliable as of this printing. However, we assume no responsibility for its use.

SALES AND SERVICE

Honeywell serves its customers through a worldwide network of sales offices, representatives and distributors. For application assistance, current specifications, pricing or name of the nearest Authorized Distributor, contact your local sales office or:

E-mail: info.sc@honeywell.com

Internet: www.honeywell.com/sensing

Phone and Fax:

| | |
|---------------|-------------------------|
| Asia Pacific | +65 6355-2828 |
| | +65 6445-3033 Fax |
| Europe | +44 (0) 1698 481481 |
| | +44 (0) 1698 481676 Fax |
| Latin America | +1-305-805-8188 |
| | +1-305-883-8257 Fax |
| USA/Canada | +1-800-537-6945 |
| | +1-815-235-6847 |
| | +1-815-235-6545 Fax |

Sensing and Control
Honeywell
1985 Douglas Drive North
Minneapolis, MN 55422
www.honeywell.com/sensing

005874-1-EN IL50 GLO Printed in USA
February 2007
Copyright © 2007 Honeywell International Inc. All rights reserved.

Honeywell