

Model MAQ14

Accelerometer



DESCRIPTION

The Model MAQ14 charge output miniature accelerometer is designed to be used in Industrial test and automation environments; including laboratory testing, modal studies and test cells where high temperatures are likely to be encountered and where space is limited and small size is desired or a high natural frequency is required. The MAQ14 is a self generating piezoelectric transducer which has no internal electronics and requires no external power for operation. These units are usually connected

to a local charge amplifier that is mounted as near as possible in a lower temperature environment. The seismic element is mechanically isolated from the mounting base, resulting in a low base strain sensitivity. The stainless steel materials are non-magnetic resulting in very low magnetic field susceptibility. These features, together with a sealed body, assure accurate and reliable data.

FEATURES

- Small size
- Charge output (pC/G)
- 18 kHz mounted frequency
- General purpose
- Side entry microdot connector

Model MAQ14

PERFORMANCE SPECIFICATIONS

Characteristic	Measure
Dynamic range	1000 G
Sensitivity	50 pC/G
Transverse sensitivity	Less than 5 %
Temperature sensitivity	0.145/°F
Frequency range	1 Hz to 10 kHz
Amplitude linearity	Better than 1 % linearity
Mounted base resonance	18 kHz

ENVIRONMENTAL SPECIFICATIONS

Characteristic	Measure
Temperature, operating	-57 °C to 249 °C [-70 °F to 480 °F]
Sealing	IP67/NEMA 4

ELECTRICAL SPECIFICATIONS

Characteristic	Measure
Input	Self generating
Standard cable length (AG910)	4,9 m [16 ft] (only AG910)
Charge amplitude required	CA2
Mating connector (AG909)	Microdot (only AG909)
Capacitance	450 pF
Isolation	Base isolated

MECHANICAL SPECIFICATIONS

Characteristic	Measure
Weight	0,03 kg [1.2 oz]
Material	Stainless steel
Mounting torque	2 ft-lb

SENSITIVITY CODES

Sensitivity Code	Sensitivity
YC	10 pC/G
YE	30 pC/G
YF	50 pC/G

WIRING CODES

Wire	
Center	(+) Output
Shield	Case ground

OPTION CODES

	Many range/option combinations are available in our quick-ship and fast-track manufacture programs. Please see http://sensing.honeywell.com/TMsensor-ship for updated listings.
Sensitivity	10 pC/G, 30 pC/G, 50 pC/G

MOUNTING DIMENSIONS

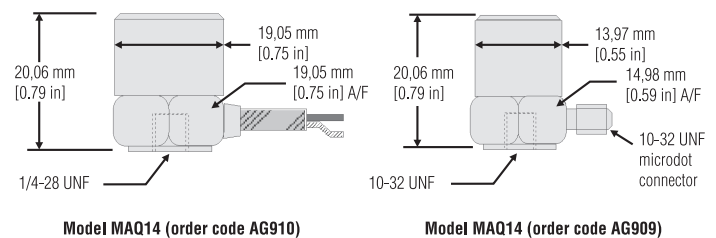

TYPICAL SYSTEM DIAGRAM

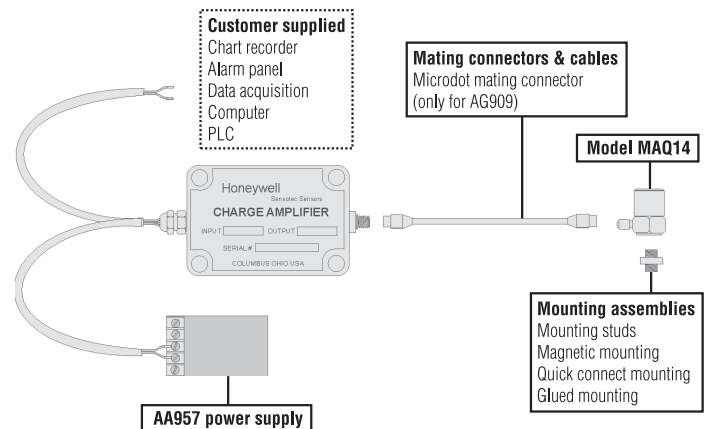

Warranty. Honeywell warrants goods of its manufacture as being free of defective materials and faulty workmanship. Honeywell's standard product warranty applies unless agreed to otherwise by Honeywell in writing; please refer to your order acknowledgement or consult your local sales office for specific warranty details. If warranted goods are returned to Honeywell during the period of coverage, Honeywell will repair or replace, at its option, without charge those items it finds defective. **The foregoing is buyer's sole remedy and is in lieu of all warranties, expressed or implied, including those of merchantability and fitness for a particular purpose. In no event shall Honeywell be liable for consequential, special, or indirect damages.**

While we provide application assistance personally, through our literature and the Honeywell web site, it is up to the customer to determine the suitability of the product in the application.

Specifications may change without notice. The information we supply is believed to be accurate and reliable as of this printing. However, we assume no responsibility for its use.

For more information about Sensing and Control products, visit www.honeywell.com/sensing or call +1-815-235-6847

Email inquiries to info.sc@honeywell.com

 **WARNING**
PERSONAL INJURY

- DO NOT USE these products as safety or emergency stop devices or in any other application where failure of the product could result in personal injury.

Failure to comply with these instructions could result in death or serious injury.

 **WARNING**
MISUSE OF DOCUMENTATION

- The information presented in this catalogue is for reference only. DO NOT USE this document as product installation information.
- Complete installation, operation and maintenance information is provided in the instructions supplied with each product.

Failure to comply with these instructions could result in death or serious injury.