

INSTALLATION INSTRUCTIONS FOR THE SPEED SENSORS, SNG-S SERIES

32347440

Issue A

GENERAL SPECIFICATIONS

Honeywell's SNG-S Series Speed Sensors use a magnetically biased Hall-effect integrated circuit (IC) to accurately sense movement of ferrous metal targets. The specially designed IC and a permanent magnet are sealed in rugged, probe-type packages. The IC detects the alteration of the magnet's flux density when it is approached by ferrous metal. A sensor

positioned at the circumference of a revolving gear wheel detects the teeth and spaces, and supplies a digital pulse output with frequency proportional to gear wheel speed. Optimum performance is dependent upon a combination of variables such as target material, geometry and speed, sensor/target gap, and environmental temperature.

TABLE 1. ELECTRICAL SPECIFICATIONS

CHARACTERISTIC	CONDITION/COMMENT	PARAMETER			
		SNG-SPRF-002	SNG-SPRD-002 SNG-SPSC-001 SNG-SPRC-001	SNG-SPRD-003 SNG-SPRC-002	SNG-SPRD-004 SNG-SPRC-003
Supply voltage	regulated supply and 12 V battery ISO 16750-2	4.5 V to 24 V –	– 8 V to 16 V	– 4.8 V to 16 V	– 4.8 V to 24 V
Supply current	–	20 mA max.		15 mA	
Reverse voltage protection	– ISO 16750-2	-24 V –		– -14 Vdc	
Over voltage protection	– ISO 16750-2	26.5 V –		– 26 V	
Short circuit protection	– ISO 16750-2	16 V –		– 16 V	
Load dump	ISO 16750-2:2012 11 01 (US* = 40 V, UA 13.5 ±0.5 V)	5b –		– –	
Insulation resistance	ISO 16750-2:2012	>10 MOhm at 500 Vdc –		– –	

TABLE 2. MECHANICAL SPECIFICATIONS

CHARACTERISTIC	PARAMETER			
	SNG-SPRF-002	SNG-SPRD-002 SNG-SPSC-001 SNG-SPRC-001	SNG-SPRD-003 SNG-SPRC-002	SNG-SPRD-004 SNG-SPRC-003
Carrier material	PBT thermoplastic		PBT	
Bushing material	SS304		SSTL	
O-ring material	70 durometer fluorocarbon, PTFE coating, 17,17 mm ID x 1,78 CS		fluorocarbon, brown, 17,17 mm ID x 1,78 CS	
Housing material	PBT		PBT	
Connector: integral mating	Bosch 928000453 Bosch 1928403966		Amp Superseal 1.5 282087	
Mounting torque	8 ±0,5 N m with M6 screw		20 ±3 N m with M8 screw	
O-ring lubrication		mineral oil-based grease		

TABLE 3. ENVIRONMENTAL SPECIFICATIONS

CHARACTERISTIC	CONDITION/COMMENT	PARAMETER	
		SNG-SPRF-002	ALL OTHER CATALOG LISTINGS
Radiated immunity	ISO 11452-2: 2004 ISO 11452-2: 2004 IEC 61000-4-3: 2008 ISO 11452-2, 400 MHz to 2.5 GHz	10 kHz to MHz, 60 m/V 200 MHz to 2.7 GHz, 100 V/m 800 kHz MHz to 1000 MHz, 3 m/V –	– – – 100 V/m
Bulk current injection	ISO 11452-4, 1 MHz to 400 MHz	100 mA	
ESD	SAE J1113/13 ISO 10605	±4 kV contact, ±8 kV air –	– ±8 kV contact, ±15 kV air
Conductive transients	ISO 7637-2, for 12 V system ISO 7637-2, for 12 V system	TEST PULSE 1, 2a, 2b, 3a, 3b –	– PULSE 1, 2a, 3a, 3b, 5a
Conducted emissions	CISPR 25. 150 kHz to 108 MHz	–	Class 3
Radiated emissions	CISPR 25. 150 kHz to 12.5 GHz	–	Class 3
Thermal cycle	-40°C to 140°C	–	100 cycles
Humidity	–	10 %RH to 90 %RH at -40°C to 85°C, 150 cycles, 600 hr total	–
	95 %RH at 55°C	–	144 hr, EN/IEC 60068-2-30
Saline dunk	0°C to 110°C	–	10 cycles, ISO 16750-4
Salt fog	5% salt solution by mass at 35°C and 93% RH for 400 hr, tested to 2000 hr with no ingress in the sensor packaging area	5% salt solution by mass at 35°C and 93% RH for 2000 hr	–
	5% salt solution by mass at 35°C	–	96 hours
Combined temperature and vibration test	sinusoidal: 25 hr/axis, 3 perpendicular axes 30 g at 60 Hz to 1000 Hz and 15 g at 1000 Hz to 2000 Hz	sinusoidal: 25 hr/axis, 3 perpendicular axes 15 g at 5 Hz to 2000 Hz	–
	random: 25 hr/axis, 3 perpendicular axes 30 g at 25 rms Hz to 2000 Hz, -40°C to 125°C	random: 25 hr/axis, 3 perpendicular axes at 25 grms at 10 Hz to 2000 Hz	–
Vibration	3 perpendicular axes, 48 hr per axis	–	29.8 GRMS, 24 Hz to 2000 Hz, MIL-STD-202-214
Degree of protection	IEC 50629 IEC 60529	IPX6, IPX9K, IPX7 –	– IP69K, IP67
Resistance to fluids	–	–	general under-the-hood automotive fluids
Operating temperature	–	-40°C to 150°C	-40°C to 140°C
Storage temperature	–	-55°C to 70°C	-40°C to 140°C

FIGURE 2. SCHEMATIC DIAGRAMS AND OUTPUT SPECIFICATIONS

SNG-SPRF-002

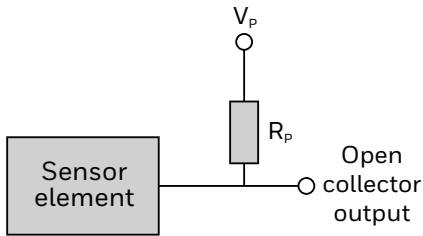

CHARACTERISTIC	CONDITION/COMMENT	PARAMETER
Signal type	open collector	square wave
Power on	–	default high and start from initial edge
Signal polarity	not dependent on target rotation	output low on teeth
Output signal: high low	– –	$\geq V_p - 0.5\text{ V}$ $\leq 0.6\text{ V}$
Load current	output leakage current -10 μA	10 mA max.
Frequency	–	0 kHz to 10 kHz

SNG-SPRD-002
SNG-SPSC-001
SNG-SPRC-001

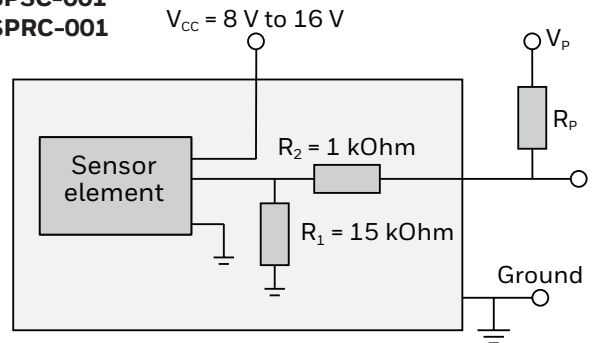

CHARACTERISTIC	CONDITION/COMMENT	PARAMETER
Signal type	open collector	square wave
Output signal: high low	dependent on target geometry and sensor-to-target orientation	$(V_p \times (16.5)) / (16.5 + R_p \text{ in kOhm})$ 0.3 V to 2.2 V $\leq ((V_p - 0.4) \times 1\text{ k}) / (1\text{ k} + R_p \text{ in kOhm}) + 0.4$
Load current	–	15 mA
Frequency	–	0 kHz to 10 kHz

SNG-SPRD-003
SNG-SPRC-002

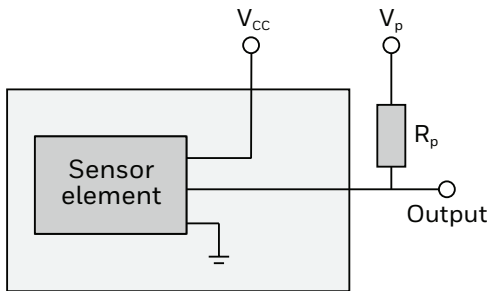

CHARACTERISTIC	CONDITION/COMMENT	PARAMETER
Signal type	open collector	square wave
Output signal: high low	dependent on the controller interface	$\geq V_{cc} - 0.5\text{ V}$ $\leq 0.5\text{ V}$
Load current	–	20 mA
Frequency	–	0 kHz to 10 kHz

SNG-SPRD-004
SNG-SPRC-003

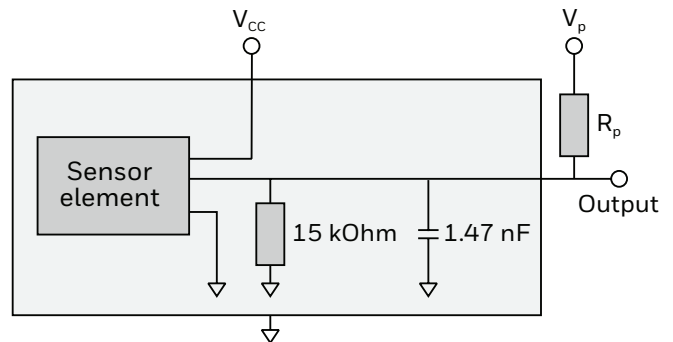

CHARACTERISTIC	CONDITION/COMMENT	PARAMETER
Signal type	open collector	square wave
Output signal: high low	dependent on the controller interface	$(V_p \times (16.5)) / (16.5 + R_p \text{ in kOhm})$ 0.5 V $< 0.5\text{ V}$
Load current	–	20 mA
Frequency	–	0 kHz to 10 kHz

FIGURE 3. MOUNTING DIMENSIONS (FOR REFERENCE ONLY: MM/[IN.])

**24 mm, right angle:
SNG-SPRF-002**

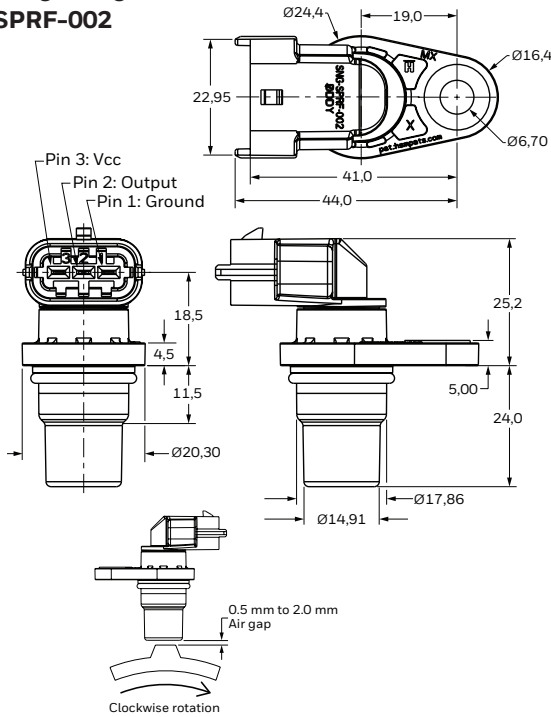

**46 mm, straight:
SNG-SPSC-001**

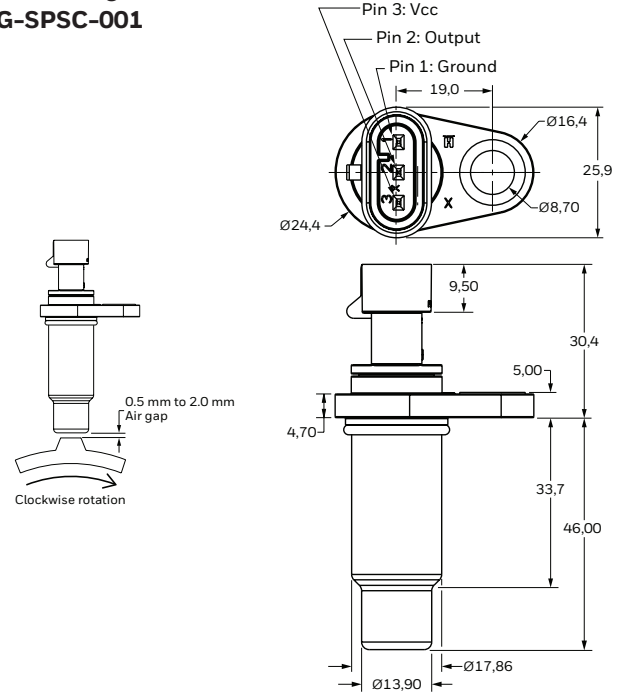

**46 mm, right angle:
SNG-SPRC-001
SNG-SPRC-002
SNG-SPRC-003**

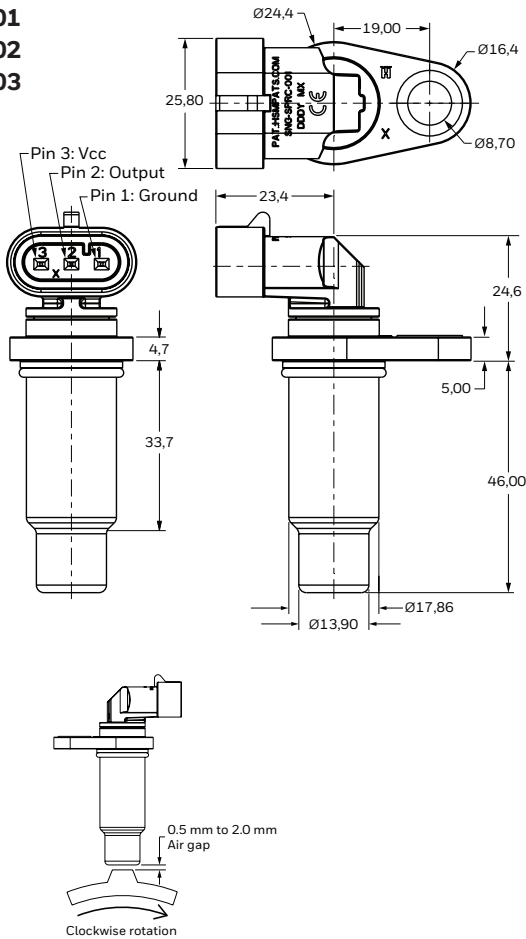

**67 mm, right angle:
SNG-SPRD-002
SNG-SPRD-003
SNG-SPRD-004**

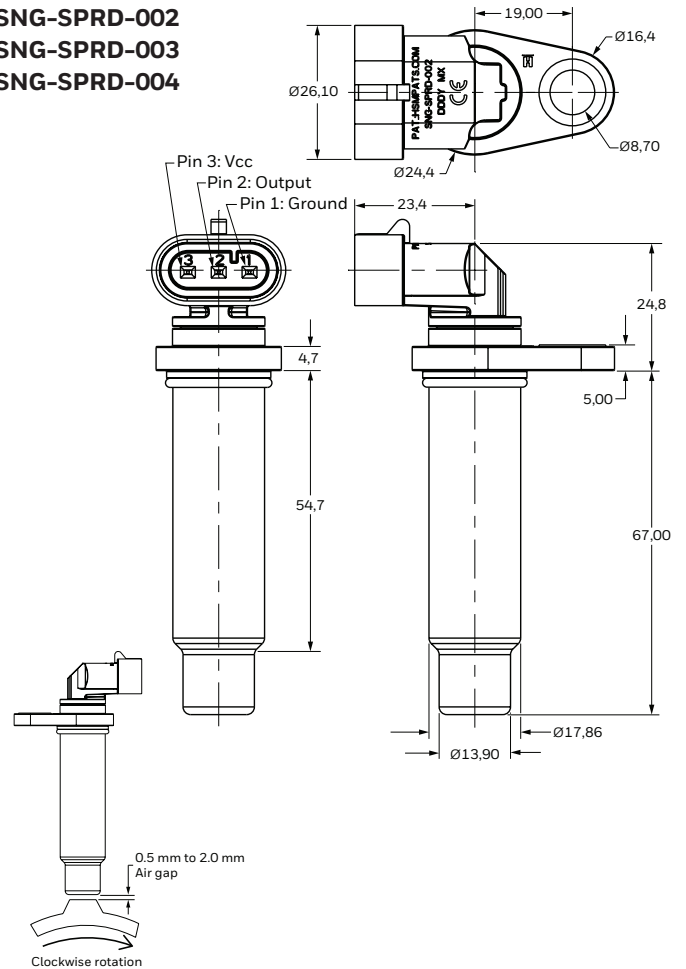
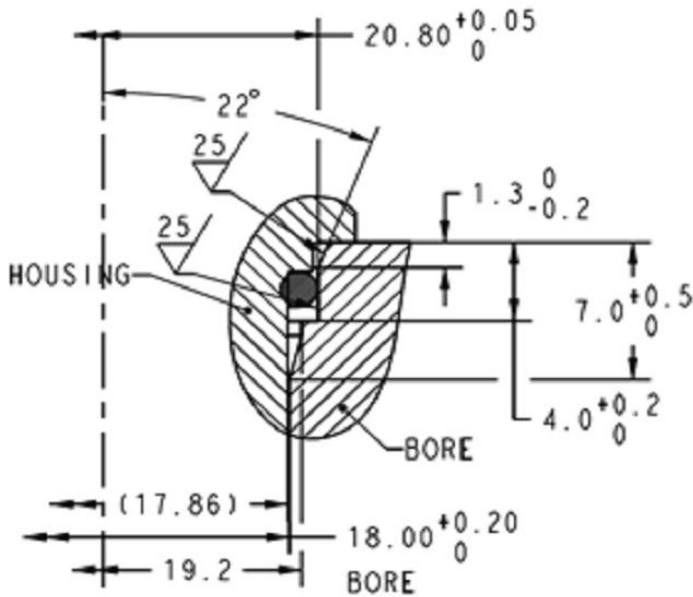

FIGURE 4. CUSTOMER INTERFACE BORE



**⚠ WARNING
PERSONAL INJURY**

DO NOT USE these products as safety or emergency stop devices or in any other application where failure of the product could result in personal injury.

Failure to comply with these instructions could result in death or serious injury.

Warranty/Remedy

Honeywell warrants goods of its manufacture as being free of defective materials and faulty workmanship during the applicable warranty period. Honeywell’s standard product warranty applies unless agreed to otherwise by Honeywell in writing; please refer to your order acknowledgment or consult your local sales office for specific warranty details. If warranted goods are returned to Honeywell during the period of coverage, Honeywell will repair or replace, at its option, without charge those items that Honeywell, in its sole discretion, finds defective. **The foregoing is buyer’s sole remedy and is in lieu of all other warranties, expressed or implied, including those of merchantability and fitness for a particular purpose. In no event shall Honeywell be liable for consequential, special, or indirect damages.**

While Honeywell may provide application assistance personally, through our literature and the Honeywell web site, it is buyer’s sole responsibility to determine the suitability of the product in the application.

Specifications may change without notice. The information we supply is believed to be accurate and reliable as of this writing. However, Honeywell assumes no responsibility for its use.

Honeywell serves its customers through a worldwide network of sales offices and distributors. For application assistance, current specifications, pricing or name of the nearest Authorized Distributor, contact your local sales office or:

- E-mail: info.sc@honeywell.com
- Internet: sensing.honeywell.com
- Phone and Fax:
 - USA/Canada +1-302-613-4491
 - International +1-815-235-6847; +1-815-235-6545 Fax

**Honeywell
Sensing and Internet of Things**

9680 Old Bailes Road
Fort Mill, SC 29707
www.honeywell.com