

## Technical Note

# Sleep Mode for Use with Honeywell Digital Pressure Sensors: ASDX Series, APB Series, and Trustability® HSC, SSC Series

### 1.0 PURPOSE

The purpose of this technical note is to provide the information necessary for using Sleep Mode in the ASDX Series, ABP Series and TruStability™ HSC Series and SSC Series Digital Output Pressure Sensor products.

### 2.0 OVERVIEW

Sleep Mode is a special factory set mode of the pressure sensor that allows the sensor to power down between necessary pressure readings. By implementing this mode, current consumption during the non-measurement time of the sensor can be reduced from 2.5 mA typ. to 0.5 µA typ.

This is ideal for applications where current consumption is more important than speed, such as battery-powered applications. The sensor only “wakes up” when sent a special command over the I<sup>2</sup>C or SPI digital communication buses, depending on the type of digital output sensor.

### 3.0 DESCRIPTION (see Figure 1)

In Sleep Mode, following the power up sequence, the sensor will power down again until the master sends a “Full Measurement Request” (either I<sup>2</sup>C or SPI) or a “Pressure Measurement Request” (I<sup>2</sup>C only) command. Specifics on the

Full Measurement Request (FMR) and Pressure Measurement Request (PMR) commands are given in Section 4.0.

A FMR or PMR wakes the sensor and starts a measurement cycle.

- **FMR:** The sensor performs a full measurement and calculation cycle, including all secondary measurements (temperature and A/D auto-zero).
- **PMR:** The sensor measures only the sensor bridge and performs the correction calculations using previously measured temperature and auto-zero data. Valid output values are then written to the digital output register and the sensor powers down again.

Following a measurement sequence, and before the next measurement can be performed, the master must send a Read Data Fetch (RDF) command, which will fetch the data as 2, 3 or 4 bytes (see Section 4.0), without waking the sensor. When an RDF is performed, the data packet returned will be the last measurement made with the status bits set to “valid”. After the RDF is completed, the status bits will be set to “stale”. The next FMR or PMR will wake the sensor again and start a new measurement cycle.

Figure 1. System Timing

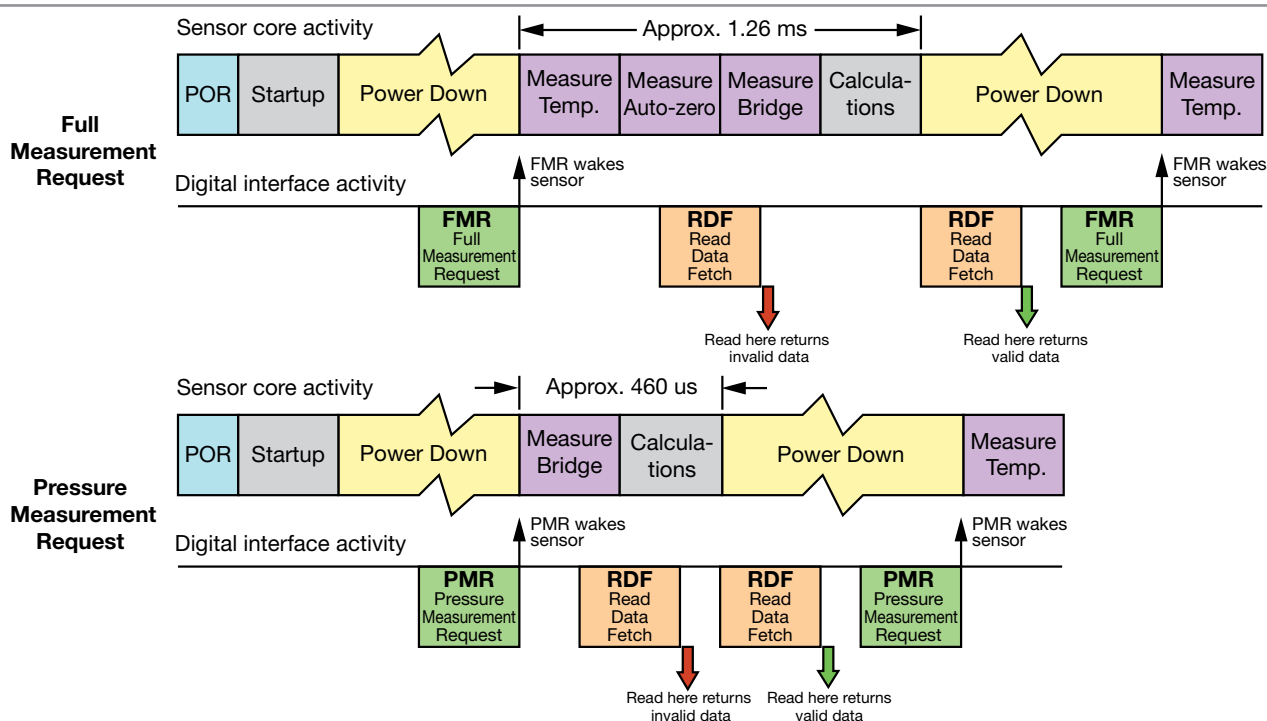

# Technical Note

## Sleep Mode for Use with Honeywell Digital Pressure Sensors: ASDX Series, APB Series, and Trustability® HSC, SSC Series

If an RDF is sent while the measurement cycle is still in progress, then the status bits of the packet will read as “stale”. The sensor should be polled at a frequency slower than 20% more than the Sleep Mode response shown in Table 1.

**Table 1. Sleep Mode Response Times<sup>1</sup>**

Measurement Request	Response Time
Full Measurement Request (FMR)	1.5 ms
Pressure Measurement Request (PMR)	0.5 ms

Note 1. Times are typical. For worst case, multiply by 1.15 (15% frequency variation).

In I<sup>2</sup>C mode only, the INT pin of the sensor will assume an interrupt function. This allows the user to monitor the interrupt pin instead of continually polling the output looking for valid data. The interrupt will indicate that the measurement and calculations are complete, and that new valid data is ready to be read on the I<sup>2</sup>C interface. (This function is only available for DIP and SMT versions.)

### 4.0 SLEEP MODE COMMANDS

#### 4.1. I<sup>2</sup>C Measurement Request Commands

##### 4.1.1. Full Measurement Request (FMR)

The command structure shown in Figure 2 is used to wake the sensor from sleep mode and perform a full measurement cycle, including secondary measurements.

**Figure 2. Command Structure for I<sup>2</sup>C FMR**

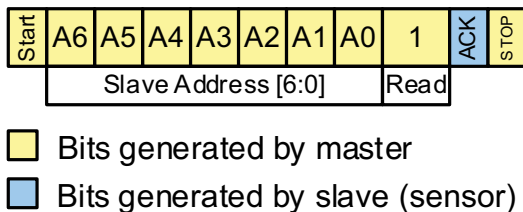

The command begins with a Start bit, followed by the seven bit address, followed by a “1”, indicating a Read. The master then waits for the sensor to generate an Acknowledge, and then immediately generates a Stop condition.

##### 4.1.2. Pressure Measurement Request (PMR) Command

The command structure shown in Figure 3 is used to wake the sensor from sleep mode and to perform a partial measurement cycle without secondary measurements. This measurement is faster than the FMR but potentially less accurate because it uses previously stored values for temperature and A/D auto-zero.

**Figure 3. Command Structure for I<sup>2</sup>C PMR**

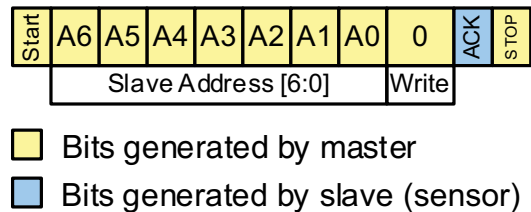

The command begins with a Start bit, followed by the seven bit address, followed by a “0”, indicating a Write. The master then waits for the sensor to generate an Acknowledge, and then immediately generates a Stop condition.

#### 4.2. SPI Full Measurement Request (FMR) Command

Because the SPI protocol is only half duplex, there are no Write conditions for the bus. Because of this, only the FMR command is available in SPI mode. Also, because of the read-only nature of SPI for Honeywell pressure sensors, the command is executed in a different manner.

The SPI FMR only requires that the SS line be dropped low for a minimum of 8 μs, then raised high again. The rise of SS will trigger the sensor to power up and perform the measurements (see Figure 4).

**Figure 4. SPI FMR Command**

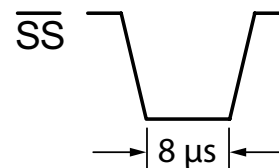

# Technical Note

## Sleep Mode for Use with Honeywell Digital Pressure Sensors: ASDX Series, APB Series, and Trustability® HSC, SSC Series

### 4.3. I<sup>2</sup>C Read Data Fetch

The I<sup>2</sup>C Read Data Fetch (RDF) command is exactly the same command that is used in the normal update (continuous) sensor mode to retrieve the data from the sensor. Data can be read out from the sensor in either two, three or four byte amounts, depending on whether temperature data is needed, and to what resolution.

The command structure for these different reads is shown in Figure 5. For more information regarding I<sup>2</sup>C read commands, please consult:

[“I<sup>2</sup>C Communications with Honeywell Digital Output Pressure Sensors” Technical Note.](#)

**Figure 5. I<sup>2</sup>C Read Data Fetch Command Structures**

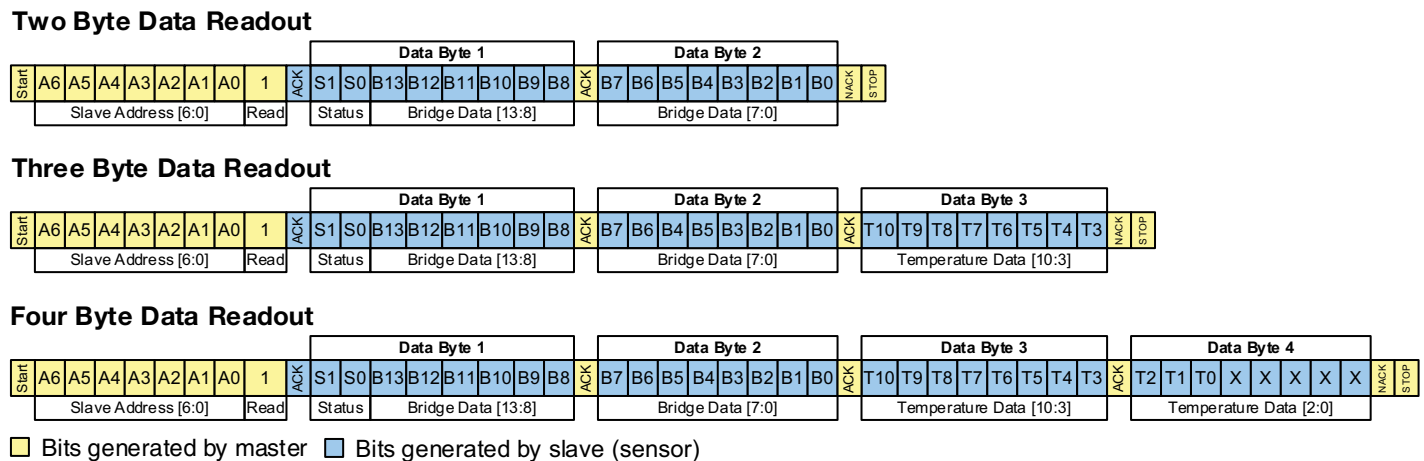

### 4.4. SPI Read Data Fetch

The SPI Read Data Fetch (RDF) is exactly the same as is used in the normal update (continuous) sensor mode to retrieve the data from the sensor. Data can be read out from the sensor in either two, three, or four byte amounts, depending on whether temperature data is needed, and to what resolution.

The command structure for these different reads in Figure 6. For more information regarding SPI data, please consult:

[“SPI Communication with Honeywell Digital Output Pressure Sensors” Technical Note.](#)

**Figure 6. SPI Read Data Fetch Command Structures**

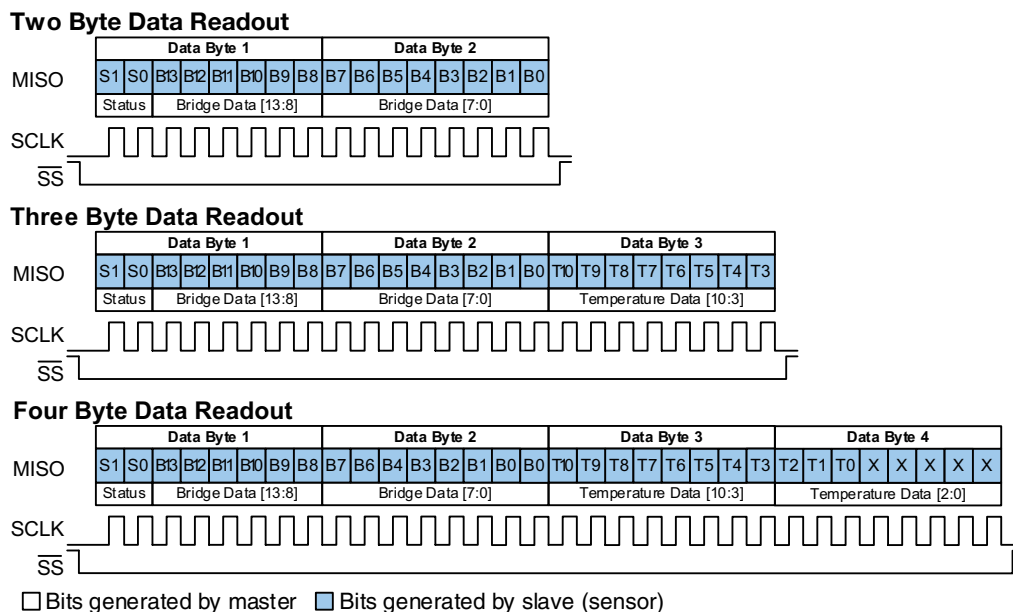

# Technical Note

## Sleep Mode for Use with Honeywell Digital Pressure Sensors: ASDX Series, APB Series, and Trustability® HSC, SSC Series

### Find out more

To learn more about Honeywell's sensing and control products, call **1-800-537-6945**, visit **sensing.honeywell.com**, or e-mail inquiries to **info.sc@honeywell.com**

Sensing and Control  
Honeywell  
1985 Douglas Drive North  
Golden Valley, MN 55422  
**honeywell.com**

**Warranty.** Honeywell warrants goods of its manufacture as being free of defective materials and faulty workmanship. Honeywell's standard product warranty applies unless agreed to otherwise by Honeywell in writing; please refer to your order acknowledgement or consult your local sales office for specific warranty details. If warranted goods are returned to Honeywell during the period of coverage, Honeywell will repair or replace, at its option, without charge those items it finds defective. **The foregoing is buyer's sole remedy and is in lieu of all warranties, expressed or implied, including those of merchantability and fitness for a particular purpose. In no event shall Honeywell be liable for consequential, special, or indirect damages.**

While we provide application assistance personally, through our literature and the Honeywell web site, it is up to the customer to determine the suitability of the product in the application.

Specifications may change without notice. The information we supply is believed to be accurate and reliable as of this printing. However, we assume no responsibility for its use.

The Honeywell logo is displayed in a bold, red, sans-serif font.