

0 Vdc to 5 Vdc Sensor Amplifier which Swings to Ground

Technical Note

INTRODUCTION

As more control systems become computerized, there is an increased need for a pressure signal output that is compatible with digital circuits. A common input requirement of many low-cost A/D converters is 0 Vdc to 5 Vdc. Unfortunately, the voltage swing of many signal conditioning amplifiers can only come within 100 mV of ground when using a single power supply. A true 0 Vdc to 5 Vdc output circuit would then require a negative power supply to allow the amplifier output to swing to ground. However, the addition of a negative power supply is often too costly or cumbersome for any given design. Therefore, a simple, low-cost solution is needed to provide a negative voltage reference for a signal conditioning amplifier such that the amplifier can swing to ground.

This technical note will discuss a pressure sensor signal conditioning circuit with a voltage converter to provide a true 0 Vdc to 5 Vdc output that swings to ground when using only a single 12 Vdc supply.

CIRCUIT DESCRIPTION

As shown in Figure 1, by using an LTC1044 (Linear Technology) voltage converter, a stable and low-cost negative supply voltage can be generated from a single 12 Vdc power supply. Here, the diode string delivers approximately 2.4 Vdc to V_1 and pin 8 on the LTC1044. By using a switched capacitor technique, capacitor C_1 will charge to voltage V_1 , and the total charge on C_1 will

be $Q_1 = C_1 V_1$. As the internal switches change position, part of Q_1 is transferred to C_2 . By continuously charging C_2 , a -2.3 voltage supply is created at the negative node of C_2 .

The negative voltage at V_2 will vary due to the diode potentials changing at V_1 and to the charge changing on C_2 . So, in order to minimize this noise which would directly affect V_{REF} and V_{OUT} in Figure 2, a micropower zener Z_1 , is used to provide a stable and low noise negative voltage supply at V_- . For the resistor values shown, the noise is less than 1 mV peak-to-peak at V_- as long as the current requirement of the amplifier is less than 2.4 mA. Additional current can be provided by increasing V_1 on the voltage converter or by reducing the resistance of R_2 .

The bandgap reference, Z_2 provides a stable and low noise positive voltage reference for the sensor excitation voltage, V_E , in Figure 2. The voltage at Z_2 is amplified to 10 Vdc for the sensor excitation voltage, so voltage variations and line noise on the 12 Vdc line will not cause sensor output errors. Similarly, the voltage at V_{REF} is held stable at the positive node by Z_2 as well as on the negative node by Z_1 .

As shown in Figure 2, the two op amp instrumentation amplifier in combination with the voltage converter shown in Figure 1 will provide a true 0 Vdc to 5 Vdc output that will swing to ground. The output equation is given as follows:

$$V_{OUT} = V_{IN} 2 \left(1 + \frac{R}{R_P + R_S} \right) + V_{REF}$$

Where: R_0 adjusts V_{REF} so that V_{OUT} equals 0.0 volts at zero pressure and R_P adjusts the full scale output such that at full pressure V_{OUT} equals 5.0 volts.

This amplifier configuration provides good common-mode rejection, high impedance inputs that do not load the sensor outputs, and a simple adjustment procedure. For the best results, use 2 % tolerance thick film resistor arrays for closely matching resistor values and low temperature coefficients. Also, use precision op amps with low offset voltage drift, and low noise characteristics. The power supply should be bypassed by C_3 to reduce line noise and voltage transients, while C_4 should be used to roll off high frequency circuit noise.

Figure 1

Negative Voltage supply for Sensor Amplifier

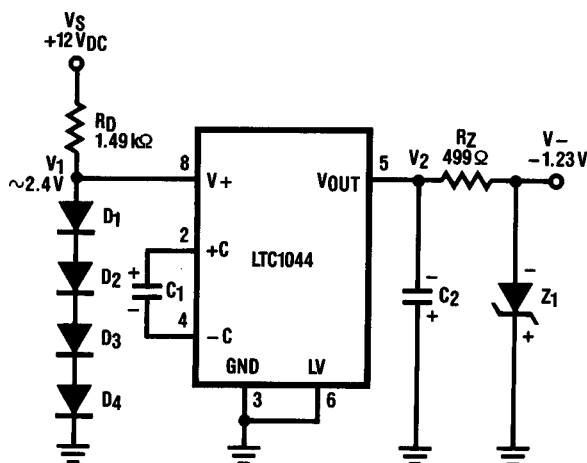

D1-D4	IN914 DIODE
Z1	LT1004CZ-1.2 (LINEAR TECHNOLOGY)
C1, C2	10 μF / 35V TANTULUM

0 Vdc to 5 Vdc Sensor Amplifier which Swings to Ground

ADJUSTMENT PROCEDURE

- Vent the sensor to atmosphere and adjust R_0 until $V_{OUT}=0.0\text{ V}$
- Apply full scale pressure to sensor and adjust R_p until $V_{OUT}=5.00\text{ Vdc}$
- Repeat (A)and(B)as necessary.

DESIGN EXAMPLE

Consider a medical respirator where the air to a patient is controlled between 0 mmHg to 250 mmHg. A single conditioning amplifier is necessary to provide a 0 Vdc to 5 Vdc input signal to an A/D converter.

By using an SCX05DN and the amplifier circuits in Figures 1 and 2, a simple interface circuit can be provided. The only calculation necessary is for the gain resistor R_T . As given in the SCX datasheet, the SCX05DN will output 60mV at $V_E=12\text{ Vdc}$ and with 5 psi (258.6 mmHg) applied. So, with $V_E=12V_{CD}$ and at 250 mmHg full pressure, the SCX05DN will output

48.3 mV. The signal gain necessary for a full-scale output of 5 Vdc is $A_V = 103\text{ V/V}$. Using the gain equation, if $R = 10\text{ kOhm}$, then $R_T = 197\text{ Ohm}$

To allow for sensor span variations, let R_s equal a 187 Ohm 1 % metal film resistor and R_p equal a 20 Ohm cermet pot. The zero pressure output can be adjusted $\pm 230\text{ mV}$ by letting R_2 equal 46.4 kOhm, R_3 equal 20 kOhm and R_0 equal a 10 kOhm cermet pot. Using the simple adjustment procedure shown previously, this circuit will provide a true 0 Vdc to 5 Vdc output for 0 mmHg to 250 mmHg. This output can then be fed directly to a number of A/D converters.

CONCLUSION

By using a voltage converter and a two op amp instrumentation amplifier, a simple 0 Vdc to 5 Vdc output that swings to ground can be provided. This output is particularly useful for interface with many A/D converters that require a 0 Vdc to 5 Vdc input range.

Figure 2
An Amplifier Circuit for a 0 mm HG - 250 mm HG Pressure Input Provides a 0 Vdc to 5 Vdc Output that Swings to Ground

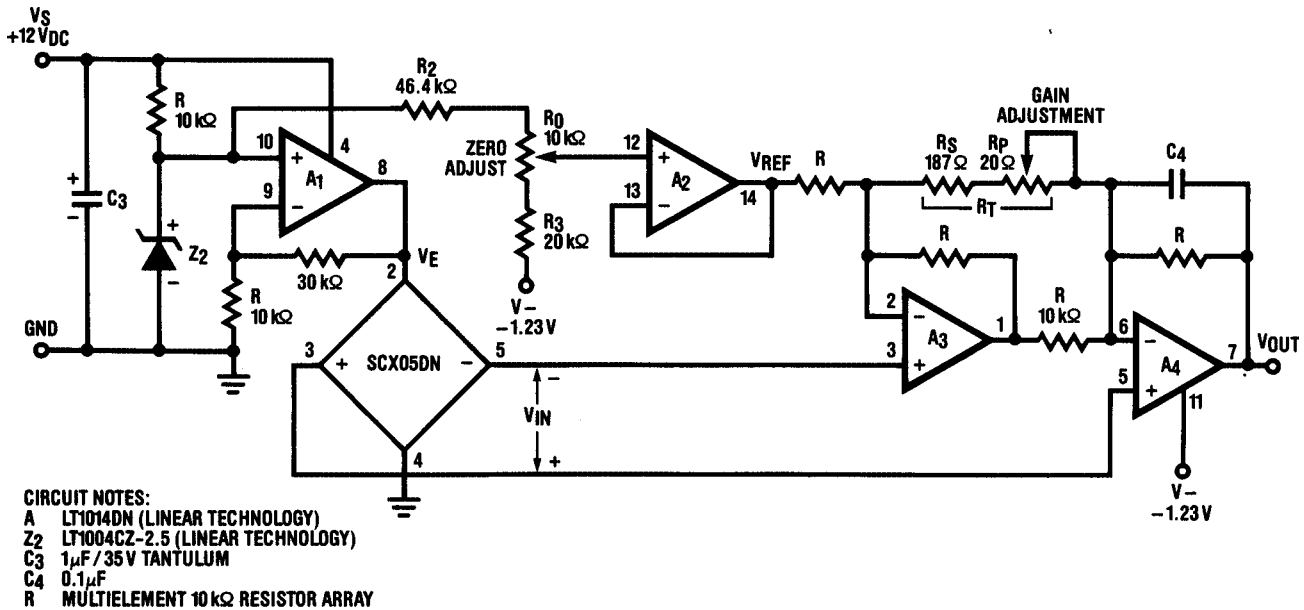

0 Vdc to 5 Vdc Sensor Amplifier which Swings to Ground

Technical Note

WARRANTY/REMEDY

Honeywell warrants goods of its manufacture as being free of defective materials and faulty workmanship. Contact your local sales office for warranty information. If warranted goods are returned to Honeywell during the period of coverage, Honeywell will repair or replace without charge those items it finds defective. **The foregoing is Buyer's sole remedy and is in lieu of all other warranties, expressed or implied, including those of merchantability and fitness for a particular purpose.**

Specifications may change without notice. The information we supply is believed to be accurate and reliable as of this printing. However, we assume no responsibility for its use.

While we provide application assistance personally, through our literature and the Honeywell web site, it is up to the customer to determine the suitability of the product in the application.

For application assistance, current specifications, or name of the nearest Authorized Distributor, check the Honeywell web site or call:

Internet:	www.honeywell.com/sensing
E-mail:	info.sc@honeywell.com
Telephone:	International 1-800-537-6945
	USA/Canada 1-815-235-6847
	United Kingdom +44 (0)1698 481 481
	France +33 1 60 19 80 40
	Germany +49 69 8064 444
	Asia Pacific +65 6355-2828
Fax:	USA 1-815-235-6545

Honeywell

Sensing and Control
www.honeywell.com/sensing
Honeywell
11 West Spring Street
Freeport, Illinois 61032