

Technical Note

I²C Communications with Honeywell Digital Airflow Sensors

1.0 Introduction

The I²C bus is a simple, serial 8-bit oriented computer bus for efficient I²C (Inter-IC) control. It provides good support for communication between different ICs across short circuit-board distances, such as interfacing microcontrollers with various low speed peripheral devices. For detailed specifications of the I²C protocol, see **I²C Bus Specification Version 2.1 January 2000**. Source: NXP Semiconductor at http://www.nxp.com/acrobat_download/literature/9398/393400_11.pdf. (Note: this link is controlled by NXP Semiconductor and is subject to change by them.)

Each device connected to the bus is software addressable by a unique address and a simple master/slave relationship that exists at all times. The output stages of devices connected to the bus are designed around an open collector architecture. Because of this, pull-up resistors to +V_{DD} must be provided on the bus.

Both SCL and SDA are bidirectional lines, and it is important to system performance to match the capacitive loads on both lines. In addition, in accordance with the I²C specification, the maximum allowable capacitance on either line is 400 pF to ensure reliable edge transitions at 400 kHz clock speeds (see Figure 1). When the bus is free, both lines are pulled up to +V_{DD}. Data on the I²C-bus can be transferred at a rate up to 100 kbit/s in the standard-mode, or up to 400 kbit/s in the fast-mode.

Figure 1. I²C Bus Configuration

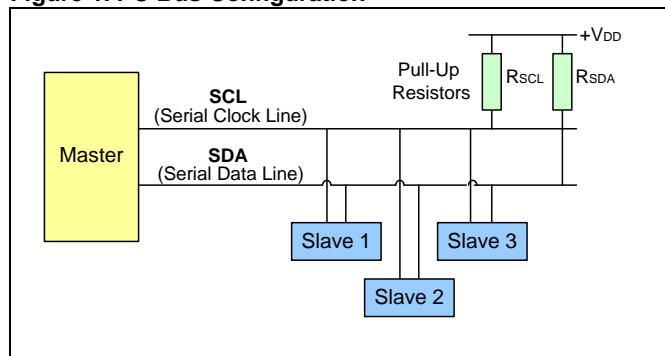

2.0 Sensor Address

Each I²C digital sensor is referenced on the bus by a 7-bit slave address. The I²C default address is 0x49; however, the address is selectable according to the Nomenclature and Order Guide in the [Honeywell Zephyr™ Digital Airflow Sensors: HAF Series- High Accuracy product data sheet](#).

(Other custom values are available. Please contact Honeywell Customer Service if there are questions regarding custom slave addresses.)

3.0 Digital Flow Reading

Honeywell's digital output airflow sensors are designed to work as slaves and will therefore only respond to requests from a master device. The sensors operate as a slave-only and the READ command structure is shown in Figure 2.

The sensors report the 0x00 or "data not ready" status until after a start-up time of ~17 ms. The first two consecutive READ commands that respond with non-zero valid data will provide the contents of two 16-bit registers with serial number information with the following format.

Serial Number Format:

Register 0

- [15:14] status in manufacturing [reserved – don't care 'XX']
- [13:9] production year
- [8:0] production day of year

Register 1

- [15:12] Model number of DUT
- [11:0] Sequential DUT number for production day

Figure 2. Standard I²C READ Command and Word Structure

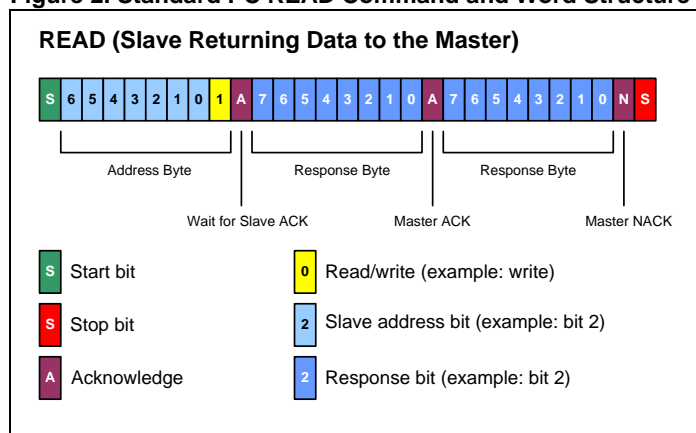

The sensor is asynchronous at start-up and will wait to supply the sequential serial number values on the first two READ commands.

After the serial number registers are read in succession, the sensor will then begin repeating 14-bit calibrated flow sensor output values updated every 1 ms (I²C 16-bit word including two leading zero bits = '00' specifying calibrated flow data packet). Table 1 shows the initial start-up sequence and subsequent data transfers of the sensor after power is applied.

I²C Communication with Honeywell Digital Airflow Sensors

Table 1. Start-up Sequence

Data	I ² C Transfer 1	I ² C Transfer 2	I ² C Transfer 3	I ² C Transfer 4
Received by airflow sensor	slave address with read bit	slave address with read bit	slave address with read bit	slave address with read bit
Command	I ² C read op	I ² C read op	I ² C read op	I ² C read op
Transmitted by airflow sensor	0x0000	Data [15:0]	Data[15:0]	{00, Data[13:0]}
Response	diagnostic low	customer Reg0	customer Reg1	corrected flow
Comment	data not ready	data ready, send serial number register 0 once	send serial number register 1 once	start sending flow for successive reads

Note: The leading 2-bits of each word of the 14-bit sensor output data are '00'.

4.0 I²C Pull-up Resistor Restrictions

A pull-up resistance is required on both the SCL and SDA lines for proper communication:

- SCL line: A resistance of 4 kOhm will work for any number of sensors.
- SDA line: See Table 2 to determine the correct resistance value.

Table 2: SDA Line Pull-Up Resistor Values

Number of Airflow Sensors on a Single I ² C Bus	Required Pull-up Resistance Value for SDA Line
1	4 kOhm
2	1.07 kOhm
3	0.550 kOhm
4	0.550 kOhm
5	0.383 kOhm
6	0.383 kOhm

5.0 I²C Addressing Issue with Honeywell Zephyr™ I²C Addresses 0x09, 0x19, 0x29, 0x39

In the event of bus communication problems in addressing or communicating with the Honeywell Zephyr™ airflow sensors with select master I²C controllers, it may be necessary to implement a “bit banging” algorithm using an I/O port directly connected to the sensor or I²C bus.

The released catalog listings in Table 3 have this addressing issue:

Table 3. Released Honeywell Zephyr Sensors with Addressing Issue

Catalog Listing	I ² C Address
HAFBLF0200C2AX3	0x29
HAFBLF0200C2AX5	
HAFBSF0200C2AX3	
HAFBSF0200C2AX5	
HAFBSS0200C2AX3	
HAFBSS0200C2AX5	

If further assistance is required, contact Honeywell Application Engineering.

6.0 Parameter Specifications and Timing

Table 4 describes the minimum and maximum limits for parameters for I²C operation with the Honeywell airflow sensors. Table 5 describes I²C timing.

I²C Communication with Honeywell Digital Airflow Sensors

Table 4. Parameters for I²C Bus Communication with Honeywell Digital Airflow Sensors

Characteristic	Sym.	Condition	Min.	Typ.	Max.	Unit	Note
Input high level	V _{IH}	–	0.9	–	1	V _{DD}	1
Input low level	V _{IL}	–	0	–	0.1	V _{DD}	1
Output low level	V _{OL}	open drain, I _{OL} = -4 mA	–	–	0.1	V _{DD}	1
Pull up current	I _{OH}	pins SCL and SDA	5	–	20	μA	–
Load capacitance SDA	C _{L,SDA}	–	–	–	400	pF	–
SCL clock frequency	f _{SCL}	–	–	–	100	kHz	–
Bus free time between STOP and START condition	t _{BUF}	–	4.7	–	–	μs	–
Hold time (repeated) START condition	t _{HD,STA}	to first clock pulse	4.0	–	–	μs	–
Low period of SCL	t _{LOW}	–	4.7	–	–	μs	–
High period of SCL	t _{HIGH}	–	4.0	–	–	μs	–
Setup time repeated start condition	t _{SU,STA}	–	4.7	–	–	μs	–
Data hold time	t _{HD,DAT}	–	0	–	–	ns	–
Data setup time	t _{SU,DAT}	–	250	–	–	ns	–
Rise time of both SDA and SCL	t _R	–	–	–	300	ns	–
Fall time of both SDA and SCL	t _F	–	–	–	300	ns	–
Set up time for stop condition	t _{SU,STO}	–	4	–	–	μs	–
Input filter spike suppression	t _{SP}	spikes on SDA or SCL of that length are suppressed	–	–	50	ns	–

Note:

1. V_{DD} is the supply voltage.

Table 5: I²C Communications Bus Timing with Honeywell Digital Airflow Sensors

Characteristic	Sym.	Condition	Min.	Typ.	Max.	Unit
High level	V _{IH}	–	0.7	–	–	V _{DDA}
Low level	V _{IL}	–	–	–	0.3	V _{DDA}
High level	V _{OH}	–	0.9	–	–	V _{DDA}
Low level	V _{OL}	–	–	–	0.1	V _{DDA}
Data setup time	T _{SETUP}	–	10	–	–	ns
Data hold time	T _{HOLD}	–	10	–	–	ns
Rise time	T _R	–	–	–	–	ns
Fall time	T _F	–	–	–	–	ns
Diagnostic output level	data	–	–	3FFF	–	hex
Data not ready	data	–	–	000	–	hex
Start condition hold time	T _{SRTHOLD}	–	1	–	–	μs
Stop condition setup time	T _{STPSETUP}	–	1	–	–	μs
Update rate	T _{UPDATE}	1 output selected at 100 kHz bus	–	280	–	μs
Update rate	T _{UPDATE}	4 outputs selected at 100 kHz bus	–	1120	–	μs
Update rate	T _{UPDATE}	1 output selected at 400 kHz bus	–	70	–	μs
Update rate	T _{UPDATE}	4 outputs selected at 400 kHz bus	–	280	–	μs

I²C Communication with Honeywell Digital Airflow Sensors

WARNING

PERSONAL INJURY

DO NOT USE these products as safety or emergency stop devices or in any other application where failure of the product could result in personal injury.

Failure to comply with these instructions could result in death or serious injury.

WARRANTY/REMEDY

Honeywell warrants goods of its manufacture as being free of defective materials and faulty workmanship. Honeywell's standard product warranty applies unless agreed to otherwise by Honeywell in writing; please refer to your order acknowledgement or consult your local sales office for specific warranty details. If warranted goods are returned to Honeywell during the period of coverage, Honeywell will repair or replace, at its option, without charge those items it finds defective. **The foregoing is buyer's sole remedy and is in lieu of all other warranties, expressed or implied, including those of merchantability and fitness for a particular purpose. In no event shall Honeywell be liable for consequential, special, or indirect damages.**

While we provide application assistance personally, through our literature and the Honeywell web site, it is up to the customer to determine the suitability of the product in the application.

Specifications may change without notice. The information we supply is believed to be accurate and reliable as of this printing. However, we assume no responsibility for its use.

WARNING

MISUSE OF DOCUMENTATION

- The information presented in this technical note is for reference only. DO NOT USE this document as a product installation guide.
- Complete installation, operation, and maintenance information is provided in the instructions supplied with each product.

Failure to comply with these instructions could result in death or serious injury.

SALES AND SERVICE

Honeywell serves its customers through a worldwide network of sales offices, representatives and distributors. For application assistance, current specifications, pricing or name of the nearest Authorized Distributor, contact your local sales office or:

E-mail: info.sc@honeywell.com

Internet: www.honeywell.com/sensing

Phone and Fax:

Asia Pacific	+65 6355-2828 +65 6445-3033 Fax
Europe	+44 (0) 1698 481481 +44 (0) 1698 481676 Fax
Latin America	+1-305-805-8188 +1-305-883-8257 Fax
USA/Canada	+1-800-537-6945 +1-815-235-6847 +1-815-235-6545 Fax

Sensing and Control
Honeywell
1985 Douglas Drive North
Golden Valley, MN 55422
www.honeywell.com/sensing

008210-3-EN
December 2011
Copyright © 2011 Honeywell International Inc. All rights reserved.

Honeywell